

USER MANUAL

SETEBOS-I

2611011024020

VERSION 1.8

MAY 8, 2026

WÜRTH ELEKTRONIK MORE THAN YOU EXPECT

MUST READ

Check for firmware updates

Before using the product, make sure you use the most recent firmware version, data sheet, and user manual. This is especially important for Wireless Connectivity products that were not purchased directly from Würth Elektronik eiSos. A firmware update on these respective products may be required.

We strongly recommend including the possibility of a firmware update in the customer system design.

Contents

Overview of helpful application notes	4
1 Revision history	7
2 Abbreviations	8
3 Introduction	9
3.1 Block diagram	10
3.2 Ordering information	10
4 Electrical specifications	11
4.1 Operating conditions	11
4.2 Absolute maximum ratings	11
4.3 Power consumption	12
4.3.1 Static	12
4.4 Radio characteristics	12
4.5 Pin characteristics	14
5 Pinout	15
6 Quick start	18
6.1 Minimal pin connections	18
6.2 Antenna connection	20
6.2.1 On-board PCB antenna	20
6.2.2 External antenna	20
7 Functional description	21
7.1 Differences - Thyone-I mode	21
8 Host connection	22
9 Firmware updates	23
10 Firmware history	24
11 Hardware history	25
12 Design in guide	26
12.1 Advice for schematic and layout	26
12.2 Designing the antenna connection	28
12.3 Antenna solutions	29
12.3.1 Wire antenna	29
12.3.2 Chip antenna	29
12.3.3 PCB antenna	30
12.3.4 Antennas provided by Würth Elektronik eiSos	30
12.3.4.1 2600130021 - Himalia dipole antenna	31

13 Reference design	32
13.1 EV-Board	33
13.2 Internal antenna radiation characteristics	36
13.3 Trace design	37
13.4 Battery powered systems	40
13.4.1 Recharging secondary cell batteries	40
13.4.2 End device testing	40
14 Manufacturing information	41
14.1 Moisture sensitivity level	41
14.2 Soldering	41
14.2.1 Reflow soldering	41
14.2.2 Cleaning	42
14.2.3 Potting and coating	43
14.2.4 Other notations	43
14.3 ESD handling	43
14.4 Safety recommendations	44
15 Product testing	45
15.1 Würth Elektronik eiSos in-house production tests	45
15.2 EMS production tests	45
16 Physical specifications	47
16.1 Dimensions	47
16.2 Weight	47
16.3 Module drawing	48
16.4 Footprint WE-FP-4+	49
16.5 Antenna free area	49
17 Marking	50
17.1 Lot number	50
17.2 General labeling information	51
18 Information for explosion protection	52
19 References	53
20 Regulatory compliance information	54
20.1 Important notice EU	54
20.2 Important notice FCC	54
20.3 Conformity assessment of the final product	54
20.4 Exemption clause	54
20.5 EU Declaration of conformity	56
20.6 RED-DA Cybersecurity statement	57
20.7 UK Declaration of conformity	59
20.8 FCC Compliance Statement (US)	60
20.8.1 FCC certificate	60
20.9 IC Compliance Statement (Canada)	61
20.9.1 IC certificate	61

20.10 FCC and IC requirements to OEM integrators	62
20.10.1 Pre-certified antennas	63
20.11 ETA-WPC (India)	64
20.11.1 ETA-WPC certificate	64
21 Important notes	66
22 Legal notice	66
23 License terms	67

Overview of helpful application notes

Application note ANR004 - Peripheral only mode

<http://www.we-online.com/ANR004>

The Bluetooth® LE modules Proteus-I,-II,-III provide the so called "peripheral only mode", that supports a serial cable replacement by offering a transparent UART bridge functionality. This document explains how to set the module into the corresponding operation mode and how to establish a Bluetooth® LE connection to a Bluetooth® LE enabled central device.

Application note ANR006 - Proteus High throughput mode

<http://www.we-online.com/ANR006>

The Proteus-II and Proteus-III provide the so called "high throughput mode". This mode sends several data packets per connection interval to increase the data throughput to a remote Bluetooth® LE device. This application note describes how to set the radio module in this mode, and how to test it in a module-to-module setup. It presents measurements and test scenarios for throughput measurements.

Application note ANR008 - Wireless Connectivity Software Development Kit

<http://www.we-online.com/ANR008>

To ease the integration of the Würth Elektronik eiSos radio modules into an application, Würth Elektronik eiSos offers the corresponding Software Development Kit (SDK) for most commonly used host processors. This SDK contains drivers and examples in C-code to communicate with the corresponding radio module. This application note shows which SDKs are available and describes how to download and use them.

Application note ANR009 - Proteus-III Advanced developer guide

<http://www.we-online.com/ANR009>

This advanced developer guide covers the details on the Proteus-III radio module that are required to implement a compatible application for smart devices. It covers the documentation on the SPP-like Bluetooth® LE profile, the used protocols and data coding for arbitrary user payload.

In addition, all information required to develop a custom firmware on the Proteus module hardware platform are provided within.

Application note ANR010 - Range estimation

<http://www.we-online.com/ANR010>

This application note presents the two most used mathematical range estimation models, Friis and two ray ground reflection, and its implementation in the range estimation tool of the RED-EXPERT.

Application note ANR014 - Proteus-I,-II,-III Quickstart

<http://www.we-online.com/ANR014>

This application note describes how to set up a Bluetooth® LE connection between one of a Proteus-I,-II,-III and a Bluetooth® LE enabled device, like a smart phone. Furthermore the data transmission via Bluetooth® LE is presented.

Application note ANR019 - Proteus-III UART vs. SPI - a comparison

<http://www.we-online.com/ANR019>

This application note shows the differences, advantages and disadvantages between the Proteus-III module with UART interface compared to the module variant with SPI slave interface.

Application note ANR020 - Proteus-III Remote GPIO control

<http://www.we-online.com/ANR020>

The Proteus-III module offers six remote controllable GPIOs that can be configured as input, output and PWM. This application note describes that feature which provides the possibility to perform simple and quick hostless operation for simple applications.

Application note ANR026 - Proteus beacons

<http://www.we-online.com/ANR026>

Besides the standard Bluetooth® LE connection based data transmission, it is possible to transmit data via Bluetooth® LE without an active connection in a broadcast message, called "Beacon". This application note describes what beacons are and how they can be used.

Application note ANR027 - Bluetooth qualification guide

<http://www.we-online.com/ANR027>

Every product containing Bluetooth® technology needs to be qualified at the Bluetooth® SIG (special interest group). This application note explains the steps to be done to gain a Bluetooth® qualification for the end product using a Würth Elektronik eiSos Bluetooth® LE radio module.

Application note ANR030 - nRF Connect

<http://www.we-online.com/ANR030>

This application note gives a short overview about the options to create a custom firmware for Würth Elektronik eiSos radio modules by using the hardware platform and the embedded nRF5x system on chip. It presents options on firmware development environments and accessories (like SDKs) for the use within the nRF5 ecosystem. The reader is informed on how to access to a multitude of radio standards (like Bluetooth® LE, Bluetooth® MESH, Bluetooth® LE Audio, Matter, Zigbee, Thread, Wirepas) for custom firmware developments whilst the hardware platform can stay the same.

Application note ANR031 - Certification of custom modules

<http://www.we-online.com/ANR031>

This application note explains how certifications of a standard product can be used to gain the certification of a customized product. This is done for firmware, which has been adapted by Würth Elektronik eiSos, as well as for firmware written by customer.

Ground plane effects on radio module antennas

<http://www.we-online.com/ANR033>

The ground plane plays a critical role in the performance of radio module antennas, affecting parameters such as radiation pattern, gain, and efficiency. This application note provides practical insights into how ground plane size, shape, and placement influence antenna behavior, offering guidance for optimal integration in real-world designs. Simulation results and measurement data are included to illustrate key effects and support design decisions.

1 Revision history

Manual version	FW version	HW version	Notes	Date
1.0	1.0.0	1.2	<ul style="list-style-type: none"> Initial release 	June 2021
1.1	1.1.0	1.2	<ul style="list-style-type: none"> Updated chapter Firmware history Added helpful application notes related to Setebos-I 	July 2022
1.2	1.1.0	1.2	<ul style="list-style-type: none"> Added chapter Internal antenna radiation characteristics 	November 2022
1.3	1.2.0	1.2	<ul style="list-style-type: none"> Added firmware version 1.2.0 to chapter Firmware history 	March 2023
1.4	1.2.0	1.2	<ul style="list-style-type: none"> Added new radio certification for UKCA in chapter 20.7 and India in chapter 20.11 	May 2023
1.5	1.2.0	1.2	<ul style="list-style-type: none"> Added certificates in addition to the required compliance statements in chapter Regulatory compliance information. 	June 2023
1.6	1.3.0	1.5	<ul style="list-style-type: none"> Added firmware version 1.3.0 to chapter Firmware history 	December 2023
1.7	1.3.0	1.5	<ul style="list-style-type: none"> Added chapter Differences - Thyone-I mode and Product testing 	October 2024
1.8	1.4.0	1.6	<ul style="list-style-type: none"> Added firmware version 1.4.0 to chapter Firmware history Added chapter Hardware history Updated CE declaration in chapter Regulatory compliance information. 	May 2026

2 Abbreviations

Abbreviation	Name	Description
EV (Board)	Evaluation (Board)	Proteus-III populated on motherboard with USB interface for test and evaluation purpose
I/O	Input/Output	Pinout description
RF	Radio frequency	Describes wireless transmission
UART	Universal Asynchronous Receiver Transmitter	Allows the serial communication with the module

3 Introduction

The Setebos-I is a radio module for wireless communication between devices such as control systems, remote controls, sensor nodes, etc. Operating in the globally available 2.4 GHz license free band, it combines two radio standards in a single hardware platform. The Setebos-I can be configured to work with either Bluetooth® LE, or the WE-ProWare radio stack.

- When selecting the Bluetooth® LE standard, the Setebos-I acts as a Proteus-III radio module.
- When selecting the WE-ProWare radio stack, the Setebos-I acts as a Thyone-I radio module.

Depending on the selected standard, the corresponding module's specifications apply. These are available in the dedicated Proteus-III [1] and Thyone-I [2] user manuals.

Small dimensions (8 x 12 mm) comparable to a nano-sim card including an on-board PCB antenna make Setebos-I ideal for small form factor design. The Setebos-I interfaces the host system via serial UART.



Figure 1: Setebos-I

3.1 Block diagram

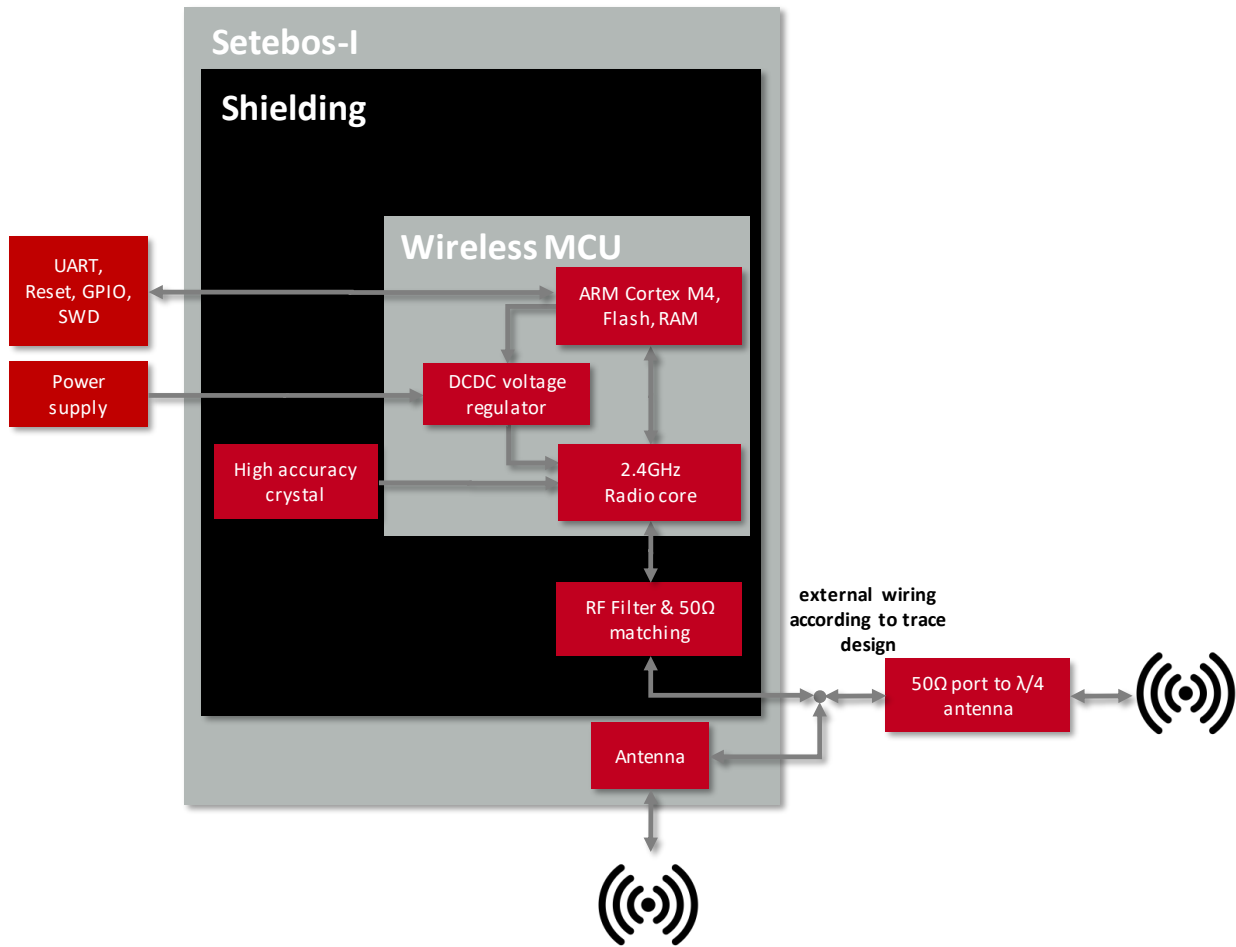

Figure 2: Block diagram of the module

3.2 Ordering information

WE order code	Description
2611011024020	Setebos-I Module, Tape & Reel
2611129024021	Mini EV-Board for Setebos-I

Table 3: Ordering information

4 Electrical specifications

As not otherwise stated measured on the EV-Board Setebos-I-EV with $T = 25\text{ °C}$, $V_{DD5} = 3\text{ V}$, $f = 2.44\text{ GHz}$, internal DC-DC converter is in use.

4.1 Operating conditions

Description	Min.	Typ.	Max.	Unit
Ambient temperature	-40	25	85	°C
Supply voltage (V _{DD5})	1.8 ¹	3	3.6	V
Supply rise time (0 V to $\geq 1.8\text{ V}$)			60	ms

Table 4: Operating conditions



The radio module may not properly boot-up for VCC rise times longer than the specified maximum. Especially for end devices powered by secondary cell batteries, special attention must be taken to meet these requirements during charging (see chapter Battery powered systems).



An unstable supply voltage may significantly decrease the radio performance and stability.

4.2 Absolute maximum ratings

Description	Min.	Typ.	Max.	Unit
Supply voltage (V _{DD})	-0.3		+3.9	V
Voltage on any digital pin, $V_{DD} \leq 3.6\text{ V}$	-0.3		$V_{DD} + 0.3$	V
Voltage on any digital pin, $V_{DD} \geq 3.6\text{ V}$	-0.3		3.9	V
Input RF level			10	dBm
Flash endurance	10 000			Write/erase cycles

Table 5: Absolute maximum ratings

¹Power fail comparator is set to 1.8 V to avoid flash fail due to voltage drop.

4.3 Power consumption

4.3.1 Static

Continuous test mode	Min.	Typ.	Max.	Unit
TX current consumption at +8 dBm		16.4 ¹		mA
TX current consumption at 0 dBm		6.4 ¹		mA
RX current consumption		6.25 ¹		mA
TX current consumption at +8 dBm		18.9 ²		mA
TX current consumption at 0 dBm		8 ²		mA
RX current consumption		7.7 ²		mA
Sleep (system off mode)		0.4		µA

Table 6: Power consumption for 100 % transmission/reception

4.4 Radio characteristics

Specifications of timing and RSSI value

Description	Min.	Typ.	Max.	Unit
RSSI accuracy valid range (±2 dB)	-90		-20	dBm
Enable TX or RX delay		140		µs
Enable TX or RX delay (fast mode)		40		µs
Disable TX delay		6		µs
Disable RX delay		0		µs

Table 7: Timing and RSSI

Description	Typ.	Unit
Output power conducted	+6	dBm
Output power integrated antenna	+4	dBm
Input sensitivity conducted (BER=1E-3, 1 Mbps)	-92	dBm
Input sensitivity integrated antenna (BER=1E-3, 1 Mbps)	-90	dBm

Table 8: Transmit and receive power

All transmit and receive power levels are measured on the EV-Board. The values already include losses of transitions from module to motherboard to SMA or modules PCB antenna. They are realistic values for the end application. Sensitivity in the table above is stated for the

¹ Transmitter only with DC/DC converter from nRF52 data sheet, CPU current not included.

² Full module power consumption.

common used bit error rate of 0.1 %. In the table below, the sensitivity is stated for a packet error rate of 1 % with a payload length of 38 bytes at different data rates. The PER 1 % is a harder criteria resulting in 2 dBm less sensitivity.

Data rate [kbit/s]	Typ.	Unit
1000 (PER 1 %)	-90	dBm
2000 (PER 1 %)	-87	dBm
500 (PER 1 %)	-94	dBm
125 (PER 1 %)	-98	dBm

Table 9: Sensitivity at different data rates

4.5 Pin characteristics

When configured as digital pin output "standard drive" is used in the Setebos-I firmware.

Description	Min.	Typ.	Max.	Unit
Input high voltage	0.7 ×VCC		VCC	V
Input low voltage	VSS		0.3 ×VCC	V
Current at VSS+0.4 V, output set low, standard drive , VDD ≥ 1.7V	1	2	4	mA
Current at VSS+0.4 V, output set low, high drive, VDD ≥ 2.7 V	6	10	15	mA
Current at VSS+0.4 V, output set low, high drive, VDD ≥ 1.7 V	3			mA
Current at VDD-0.4 V, output set high, standard drive , VCC ≥ 1.7V	1	2	4	mA
Current at VDD-0.4 V, output set high, high drive, VDD ≥ 2.7 V	6	9	14	mA
Current at VDD-0.4 V, output set high, high drive, VDD ≥ 1.7 V	3			mA
Internal pull-up resistance	11	13	16	kΩ
Internal pull-down resistance	11	13	16	kΩ

Table 10: Pin characteristics

5 Pinout

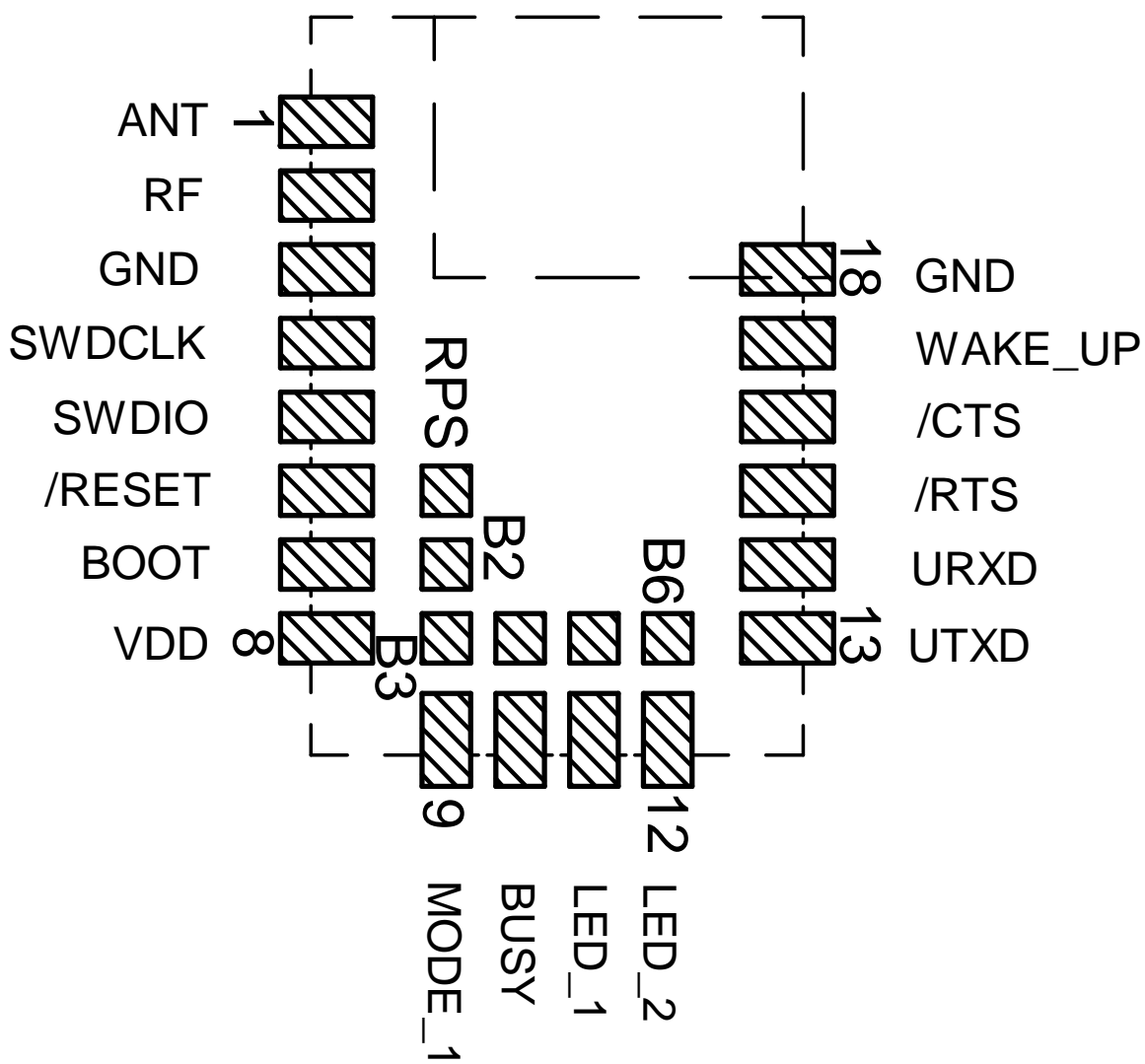

Figure 3: Pinout (top view)

No	μC Pin	Designation	I/O	Description
1		<i>ANT</i>	I/O	RF connection to PCB antenna. (see section 6.2)
2		<i>RF</i>	I/O	50 Ω RF connection through radio front end to transceiver part of chipset. (see section 6.2)
3		<i>GND</i>	Supply	Ground
4		<i>SWDCLK</i>	Input	Serial wire clock (SWD Interface). Uses internal pull down resistor. Do not connect if not needed.
5		<i>SWDIO</i>	Input	Serial wire input/output (SWD Interface). Uses internal pull up resistor. Do not connect if not needed.
6	P0.18	<i>/RESET</i>	Input	Reset pin. A low signal resets the module. Uses internal pull up resistor.
7	P0.02	<i>BOOT</i>	Input	Boot pin. A low signal during and short after reset starts the module in OTA bootloader mode. Uses internal pull up resistor ¹ . Do not connect if not needed.
8		<i>VDD</i>	Supply	Supply voltage
9	P0.19	<i>MODE_1</i>	Input	Operation mode pin with internal pull down resistor ¹ during start-up. Low level or open: Normal Mode. High level: Peripheral only Mode. Do not connect if not needed.
10	P0.22	<i>BUSY</i>	Output	Indicates if module is busy with data transmission when using Peripheral only Mode/Transparent Mode. Do not connect, if not needed.
11	P0.00/XL1 ²	<i>LED_1</i>	Output	Indicates the module state (active high). Do not connect if not needed.
12	P0.01/XL2 ²	<i>LED_2</i>	Output	Indicates the module state (active high). Do not connect if not needed.
13	P1.08	<i>UTXD</i>	Output	UART (Transmission)
14	P1.09	<i>URXD</i>	Input	UART (Reception). Uses internal pull up resistor ¹ .
15	P0.11	<i>/RTS</i>	Output	/RTS signal, if flow control is enabled. Static low, otherwise. Do not connect if not needed.
16	P0.12	<i>/CTS</i>	Input	/CTS signal, if flow control is enabled. Using internal pull down ¹ , otherwise. Do not connect if not needed.
17	P0.03	<i>WAKE_UP</i>	Input	Wake-up will allow leaving the system-off mode or re-enabling the UART. Uses internal pull up resistor ¹ . Do not connect if not needed.
18		<i>GND</i>	Supply	Ground

B1	P0.09/NFC1	<i>RPS</i>	Input	Radio protocol selection pin. A low level during and shortly after reset starts the Proteus-III function. A high level during and shortly after reset starts the Thyone-I function. Uses internal pull down resistor ¹ .
B2	P0.10/NFC2	<i>B2</i>	GPIO	Pin for remote GPIO access. Do not connect, if not needed.
B3	P0.23	<i>B3</i>	GPIO	Pin for remote GPIO access. Do not connect, if not needed.
B4	P1.00	<i>B4</i>	GPIO	Pin for remote GPIO access. Do not connect, if not needed.
B5	P0.21	<i>B5</i>	GPIO	Pin for remote GPIO access. Do not connect, if not needed.
B6	P0.07	<i>B6</i>	GPIO	Pin for remote GPIO access. Do not connect, if not needed.

Table 11: Pinout

¹Internal pull-ups or pull-downs are configured at startup by the firmware installed in the SoC. The pull up on the /RESET pin cannot be disabled by firmware.

²Pins available to connect an external crystal in custom firmware. The standard firmware of Setebos-I does not implement this function.

6 Quick start

The Setebos-I module comes pre-flashed, tested and ready to use out-of-the-box. This chapter describes the steps to quickly build a prototype system and test the capabilities of the module. Depending on the radio protocol in use (Bluetooth Low Energy 5.1 or Proprietary), specific quick start information and examples can be found in the Proteus-III [1] and Thyone-I [2] user manuals.

6.1 Minimal pin connections

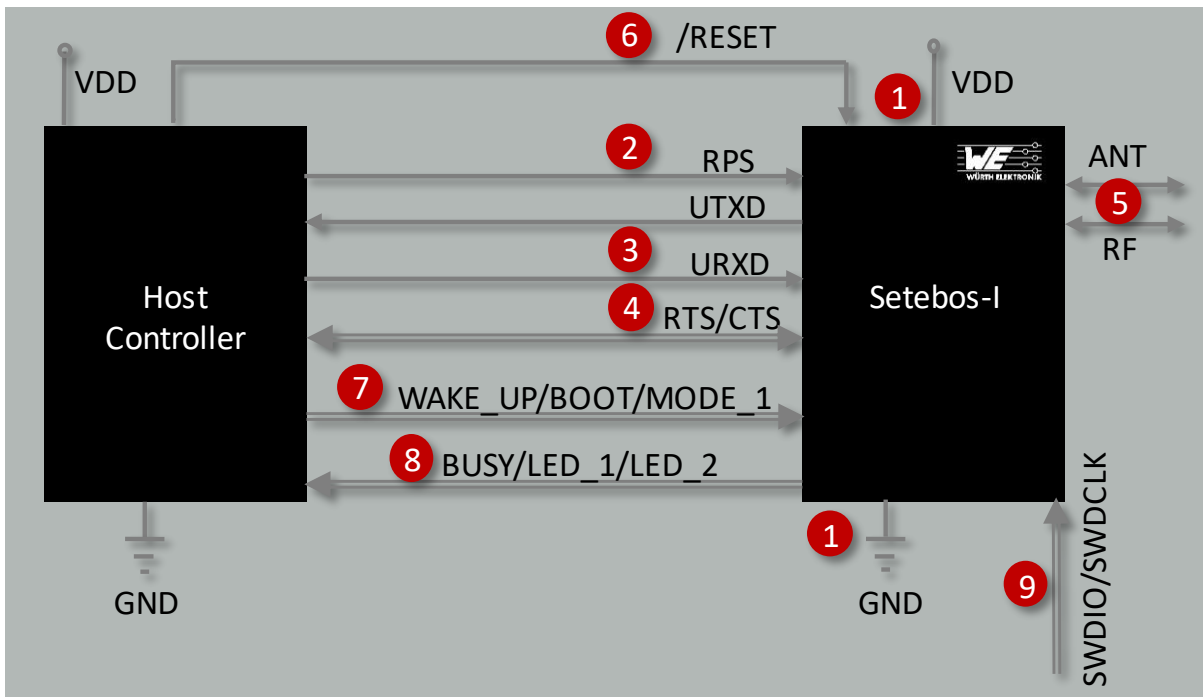

Figure 4: Minimal pin connections

The above image shows the steps to be performed to integrate the Setebos-I into a custom end device.

1. Supply voltage and ground
Connect the *VDD* and *GND* pins to supply the radio module with power.
2. Radio standard selection
Connect the *RPS* to the host controller to select the desired radio standard.
3. UART serial interface to the host
Connect the UART pins *UTXD* and *URXD* to the host to communicate with and control the module via the host.

4. UART flow control

In case of fast UART baud rates higher than 115.2 kbaud the UART flow control is activated automatically. For lower data rates the flow control is inactive per default. If activated the */RTS* and */CTS* pins must be connected to the host controller.

5. Antenna connection

The antenna configuration must be performed. See chapter 6.2.

6. Reset

Connect the */RESET* pin to the host to allow a hard reset of the module.

7. (Optional) Wakeup from sleep, FOTA and mode selection

- Connect the *WAKE_UP* pin to the host controller to leave power saving modes, like the sleep mode.
- Connect the *BOOT* pin to the host controller to set the module into boot mode to enable firmware updates via radio.
- Connect the *MODE_1* pin to the host controller to switch between command and peripheral only mode.

8. (Optional) Status indication

Connect the *BUSY*, *LED_1* and *LED_2* pins to the host controller to allow easy indication of the status.

9. (Optional) Flash and debug interface

In case of custom firmware development, it is recommended to additionally have the pins *SWDIO* and *SWDCLK* accessible in order to support a fail-safe update of firmware. A standard socket on the customer's PCB for connecting a flash adapter can be useful for debugging purposes (e.g. a JTAG 2*10 pin header with 2.54 mm pin-to-pin distance).

If the module has to be connected to a PC, a converter (TTL to RS-232 or TTL to USB) has to be used. See chapter 5 for details on all pins. Please refer to the Setebos-I-EV schemes for a reference design.



The logic level of the module is based on 3V. A 5 V logic level must not be connected directly to the module.

6.2 Antenna connection

Setebos-I's smart antenna configuration enables the user to choose between two antenna options:

6.2.1 On-board PCB antenna

The Setebos-I has an on-board PCB antenna optimized for strong miniaturization operating in the 2.4 GHz frequency band. A simple short between the pins *RF* and *ANT* feeds the RF output of the module to the on-board antenna of the Setebos-I. In this configuration, the module does not require any additional RF circuitry. For US and Canada, please refer to the trace design in chapter 13.3.

6.2.2 External antenna

For applications that use an external antenna, the Setebos-I provides a 50 Ω RF signal on pin *RF* of the module. In this configuration, pin *ANT* of the module has to be connected to ground and pin *RF* to the external antenna via 50 Ω feed line. Refer to chapter 13 for further information.



The use cases for the integrated antenna are miniaturization and re-use of module certifications for the end-application. The use cases for the external antenna are optimization of radio range spending more space for the antenna and differentiated antenna for example when metal housings are used.

7 Functional description

The Setebos-I module integrates the Bluetooth® LE 5.1 and the Würth Elektronik eiSos proprietary radio protocol in a single device. The *RPS* pin allows the user to switch between Bluetooth® and proprietary radio (please refer to Chapter 5).

- A low level during and shortly after reset starts the Bluetooth® LE 5.1 firmware. In this case, the functional description of the Proteus-III radio module applies. This can be found in chapter 5 of the Proteus-III user manual [1].
- A high level during and shortly after reset starts the WE-ProWare firmware. In this case, the functional description of the Thyone-I radio module applies. This can be found in chapter 5 of the Thyone-I user manual [2].

Example:

That means when requesting the firmware version of the Setebos-I by a UART command, the radio module will return the firmware version of the integrated Proteus-III, in case the Setebos-I has been started as Proteus-III. It will return the firmware version of the integrated Thyone-I, in case it has been started as Thyone-I.

7.1 Differences - Thyone-I mode

In contrast to a standard Thyone-I the Setebos-I implements OTAP (over the air firmware programming) using the secure bootloader via Bluetooth® LE (Proteus-III function).

Thus when Setebos-I is acting as Thyone-I the command `CMD_BOOTLOADER_REQ` will time out (i.e. send no reply) as it is not available.

When the Setebos-I is acting as Proteus-III the command `CMD_BOOTLOADER_REQ` is still available. To update the firmware on a Setebos-I please proceed with the method OTAP in Proteus-III mode as described in chapter 9.

8 Host connection

The Setebos-I is intended to be used as a radio module in a system, interfaced with a host micro-controller. The use of industry standard UART as the primary interface ensures a very minimal requirement set on the host MCU. As a result of this, the module can be designed in with most host controllers from an 8051 to the more advanced ARM core architecture.

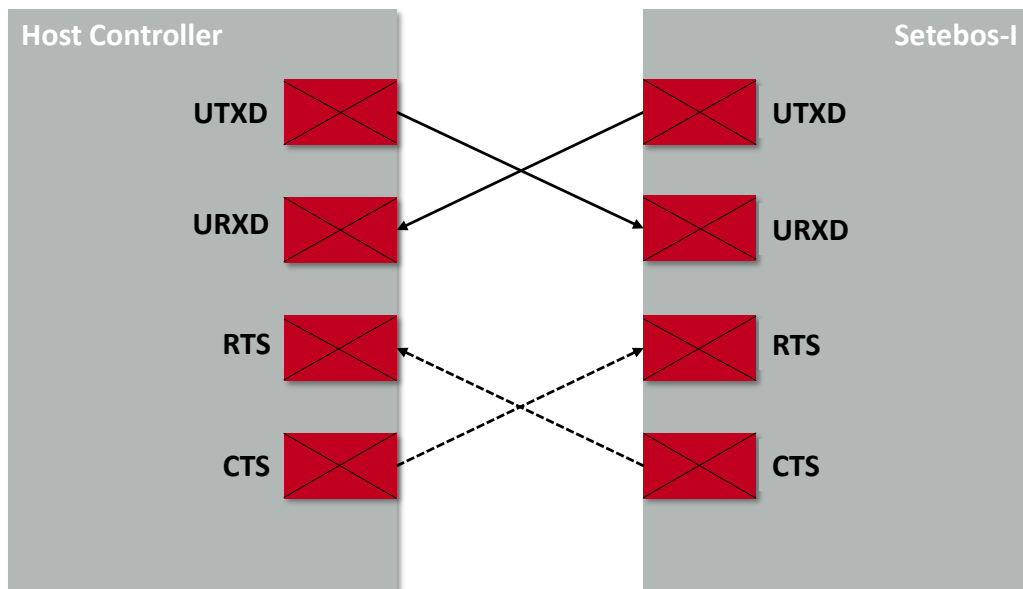

Figure 5: Host Interface

Depending on the selected standard (Bluetooth Low Energy 5.1 or Proprietary), the corresponding characteristics apply. These are available in the dedicated Proteus-III [1] and Thyone-I [2] user manuals.

9 Firmware updates

All products will experience maintenance, security and/or feature updates from time to time. For the standard products these are maintained via the PCN process.

Customers can request the creation of a customized product including a "firmware freeze" to ensure that they will receive their verified product even if the standard product is updated.

The Setebos-I uses the OTAP (over the air programming) update procedure of the Proteus-III radio module. The OTAP mode can be enabled using the *BOOT* pin or the respective Proteus-III UART command. For more details, please refer to the Proteus-III user manual [1].



Please note that only Setebos-I OTA firmware images can be loaded on the Setebos-I. Separate Proteus-III or Thyone-I OTA firmware images will be blocked by the bootloader.

10 Firmware history

Version 1.0.0 "Release"

- First production release
- Includes Proteus-III firmware version 1.3.0
- Includes Thyone-I firmware version 1.5.0

Version 1.1.0 "Release"

- Includes Proteus-III firmware version 1.4.0
- Includes Thyone-I firmware version 1.6.0

Version 1.2.0 "Release" August 13th 2023

- Includes Proteus-III firmware version 1.4.0
- Includes Thyone-I firmware version 1.7.0

Version 1.3.0 "Release" March 1st 2024

- Includes Proteus-III firmware version 1.5.0
- Includes Thyone-I firmware version 1.7.0

Version 1.4.0 "Release" April 1st 2026

- Includes Proteus-III firmware version 1.5.0
- Includes Thyone-I firmware version 1.10.0



For more details, see Proteus-III [1] and Thyone-I [2] user manuals.

11 Hardware history

Version 1.4 "Release"

- First production release
- nRF52840, WLCSP, revision 2

Version 1.5 "New Chip revision"

- nRF52840, WLCSP, revision 3

Version 1.6 "Second Source. Effective Date: 2026-07-03"

- To meet current customer demands, Würth Elektronik eiSos has added a second qualified supplier for components in the Bill of Materials to strengthen supply chain robustness.
- There will be no change in form, fit, function, quality or reliability of the product.
- The new hardware version 1.6 may include either the existing or the newly qualified components.

12 Design in guide

12.1 Advice for schematic and layout

For users with less RF experience it is advisable to closely copy the relating EV-Board with respect to schematic and layout, as it is a proven design. The layout should be conducted with particular care, because even small deficiencies could affect the radio performance and its range or even the conformity.

The following general advice should be taken into consideration:

- A clean, stable power supply is strongly recommended. Interference, especially oscillation can severely restrain range and conformity.
- Variations in voltage level should be avoided.
- LDOs, properly designed in, usually deliver a proper regulated voltage.
- Blocking capacitors and a ferrite bead in the power supply line can be included to filter and smoothen the supply voltage when necessary.
- Elements for ESD protection should be placed on all pins that are accessible from the outside and should be placed close to the accessible area. For example, the RF-pin is accessible when using an external antenna and should be protected.
- ESD protection for the antenna connection must be chosen such as to have a minimum effect on the RF signal. For example, a protection diode with low capacitance such as the 8231606A or a 68 nH air-core coil connecting the RF-line to ground give good results.
- Placeholders for optional antenna matching or additional filtering are recommended.
- The antenna path should be kept as short as possible.
- The use of an external reset IC should be considered if one of the following points is relevant:
 - The slew rate of the power supply exceeds the electrical specifications.
 - The effect of different current consumptions on the voltage level of batteries or voltage regulators should be considered. The module draws higher currents in certain scenarios like start-up or radio transmit which may lead to a voltage drop on the supply. A restart under such circumstances should be prevented by ensuring that the supply voltage does not drop below the minimum specifications.
 - Voltage levels below the minimum recommended voltage level may lead to malfunction. The reset pin of the module shall be held on LOW logic level whenever the VDD is not stable or below the minimum operating Voltage.
 - Special care must be taken in case of battery powered systems.
- To avoid the risk of short circuits and interference there should be no routing underneath the module on the top layer of the baseboard.
- On the second layer, a ground plane is recommended, to provide good grounding and shielding to any following layers and application environment.

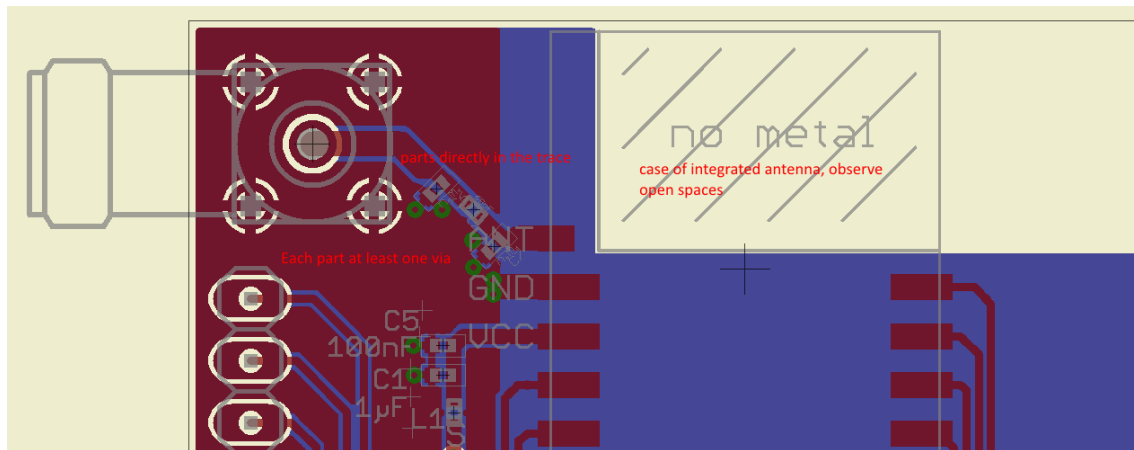

Figure 6: Layout

- In case of integrated antennas it is required to have areas free from ground. This area should be copied from the EV-Board.
- The area with the integrated antenna must overlap with the carrier board and should not protrude, as it is matched to sitting directly on top of a PCB.
- Modules with integrated antennas should be placed with the antenna at the edge of the main board. It should not be placed in the middle of the main board or far away from the edge. This is to avoid tracks beside the antenna.
- Filter and blocking capacitors should be placed directly in the tracks without stubs, to achieve the best effect.
- Antenna matching elements should be placed close to the antenna / connector, blocking capacitors close to the module.
- Ground connections for the module and the capacitors should be kept as short as possible and with at least one separate through hole connection to the ground layer.
- ESD protection elements should be placed as close as possible to the exposed areas.



Fixed values can not be recommended, as these depend on the circumstances of the application (main power source, interferences etc.).

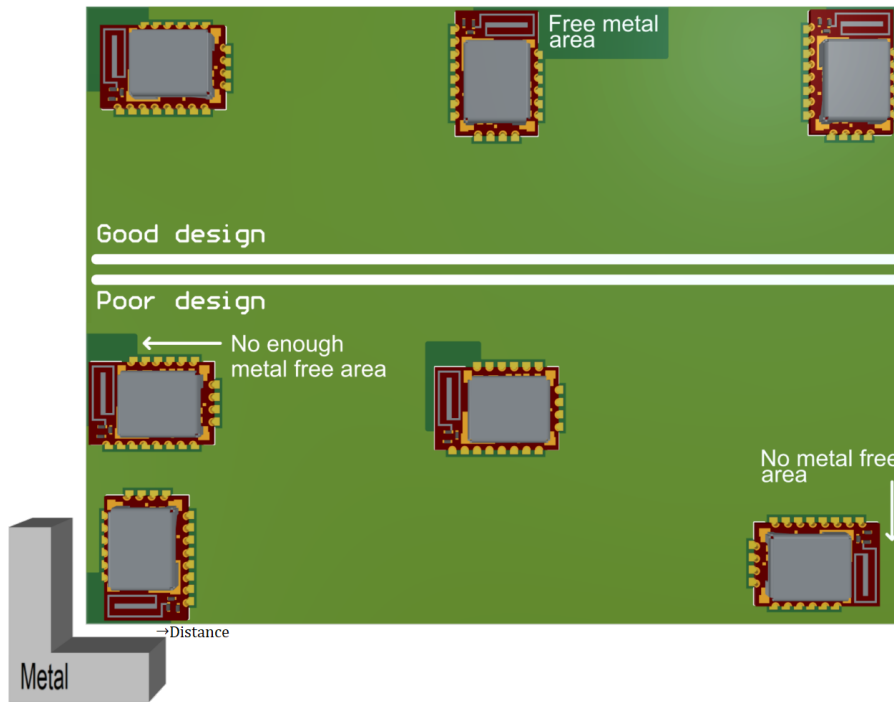

Figure 7: Placement of the module with integrated antenna

12.2 Designing the antenna connection

The antenna should be connected with a 50 Ω line. This is needed to obtain impedance matching to the module and avoids reflections. Here we show as an example how to calculate the dimensions of a 50 Ω line in form of a micro strip above ground, as this is easiest to calculate. Other connections like coplanar or strip line are more complicated to calculate but can offer more robustness to EMC. There are free calculation tools available in the internet.

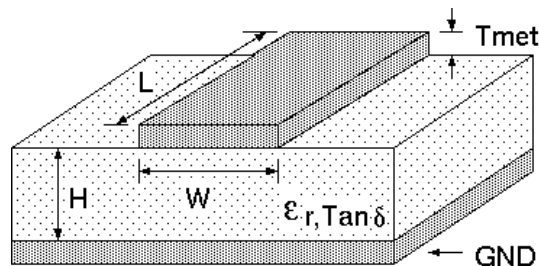

Figure 8: Dimensioning the antenna connection as micro strip

The width W for a micro strip can be calculated using the following equation:

$$W = 1.25 \times \left(\frac{5.98 \times H}{e^{\frac{50 \times \sqrt{\epsilon_r + 1.41}}{87}}} - T_{met} \right)$$

Example:

A FR4 material with $\epsilon_r = 4.3$, a height $H = 1000 \mu\text{m}$ and a copper thickness of $T_{met} = 18 \mu\text{m}$ will lead to a trace width of $W \sim 1.9 \text{ mm}$. To ease the calculation of the micro strip line (or e.g. a

coplanar) many calculators can be found in the internet.

- As rule of thumb a distance of about $3 \times W$ should be observed between the micro strip and other traces / ground.
- The micro strip refers to ground, therefore there has to be the ground plane underneath the trace.
- Keep the feeding line as short as possible.

12.3 Antenna solutions

There exist several kinds of antennas, which are optimized for different needs. Chip antennas are optimized for minimal size requirements but at the expense of range, PCB antennas are optimized for minimal costs, and are generally a compromise between size and range. Both usually fit inside a housing.

Range optimization in general is at the expense of space. Antennas that are bigger in size, so that they would probably not fit in a small housing, are usually equipped with a RF connector. A benefit of this connector may be to use it to lead the RF signal through a metal plate (e.g. metal housing, cabinet).

As a rule of thumb a minimum distance of $\lambda / 10$ (which is 3.5 cm @ 868 MHz and 1.2 cm @ 2.44 GHz) from the antenna to any other metal should be kept. Metal placed further away will not directly influence the behavior of the antenna, but will anyway produce shadowing.



Keep the antenna as far as possible from large metal objects to avoid electromagnetic field blocking.

In the following chapters, some special types of antenna are described.

12.3.1 Wire antenna

An effective antenna is a $\lambda / 4$ radiator with a suiting ground plane. The simplest realization is a piece of wire. It's length is depending on the used radio frequency, so for example 8.6 cm 868.0 MHz and 3.1 cm for 2.440 GHz as frequency. This radiator needs a ground plane at its feeding point. Ideally, it is placed vertically in the middle of the ground plane. As this is often not possible because of space requirements, a suitable compromise is to bend the wire away from the PCB respective to the ground plane. The $\lambda / 4$ radiator has approximately 40Ω input impedance. Therefore, matching is not required.

12.3.2 Chip antenna

There are many chip antennas from various manufacturers. The benefit of a chip antenna is obviously the minimal space required and reasonable costs. However, this is often at the expense of range. For the chip antennas, reference designs should be followed as closely as possible, because only in this constellation can the stated performance be achieved.

12.3.3 PCB antenna

PCB antenna designs can be very different. The special attention can be on the miniaturization or on the performance. The benefits of the PCB antenna are their small / not existing (if PCB space is available) costs, however the EV of a PCB antenna holds more risk of failure than the use of a finished antenna. Most PCB antenna designs are a compromise of range and space between chip antennas and connector antennas.

12.3.4 Antennas provided by Würth Elektronik eiSos

Besides the radio modules Würth Elektronik eiSos provides various antennas tailored for the different frequency bands. The recommended single external antennas are shown in the subsequent chapters.



In case integrated multilayer chip antennas are needed because of space limitations, please refer to <https://www.we-online.com/en/components/products/WE-MCA>.

12.3.4.1 2600130021 - Himalia dipole antenna



Figure 9: Himalia dipole antenna

Due to the fact that the antenna has dipole topology, there is no need for an additional ground plane. Nevertheless, the specification was measured edge mounted and 90 ° bent on a 100 x 100 mm ground plane.

Specification	Value
Frequency range [GHz]	2.4 – 2.5
Impedance [Ω]	50
VSWR	$\leq 2:1$
Polarization	Linear
Radiation	Omni-Directional
Peak Gain [dBi]	2.8
Average Gain [dBi]	-0.6
Efficiency	85 %
Dimensions (L x d) [mm]	83.1 x 10
Weight [g]	7.4
Connector	SMA plug
Operating temp. [$^{\circ}\text{C}$]	-40 – +80

Special care must be taken for FCC certification when using this external antenna to fulfill the requirement of permanently attached antenna or unique coupling, for example by using the certified dipole antenna in a closed housing, so that it is possible to remove it only through professional installation.

13 Reference design

The module was tested and certified on the corresponding EV-Board. For the European Conformity the EV-Board serves as reference design. For the FCC the EV-Board serves as trace design (chapter 13.3) that has to be followed when referencing the module FCC ID. The certification runs on Proteus-III and is valid for the Setebos-I by a class 1 permissive change.

13.1 EV-Board

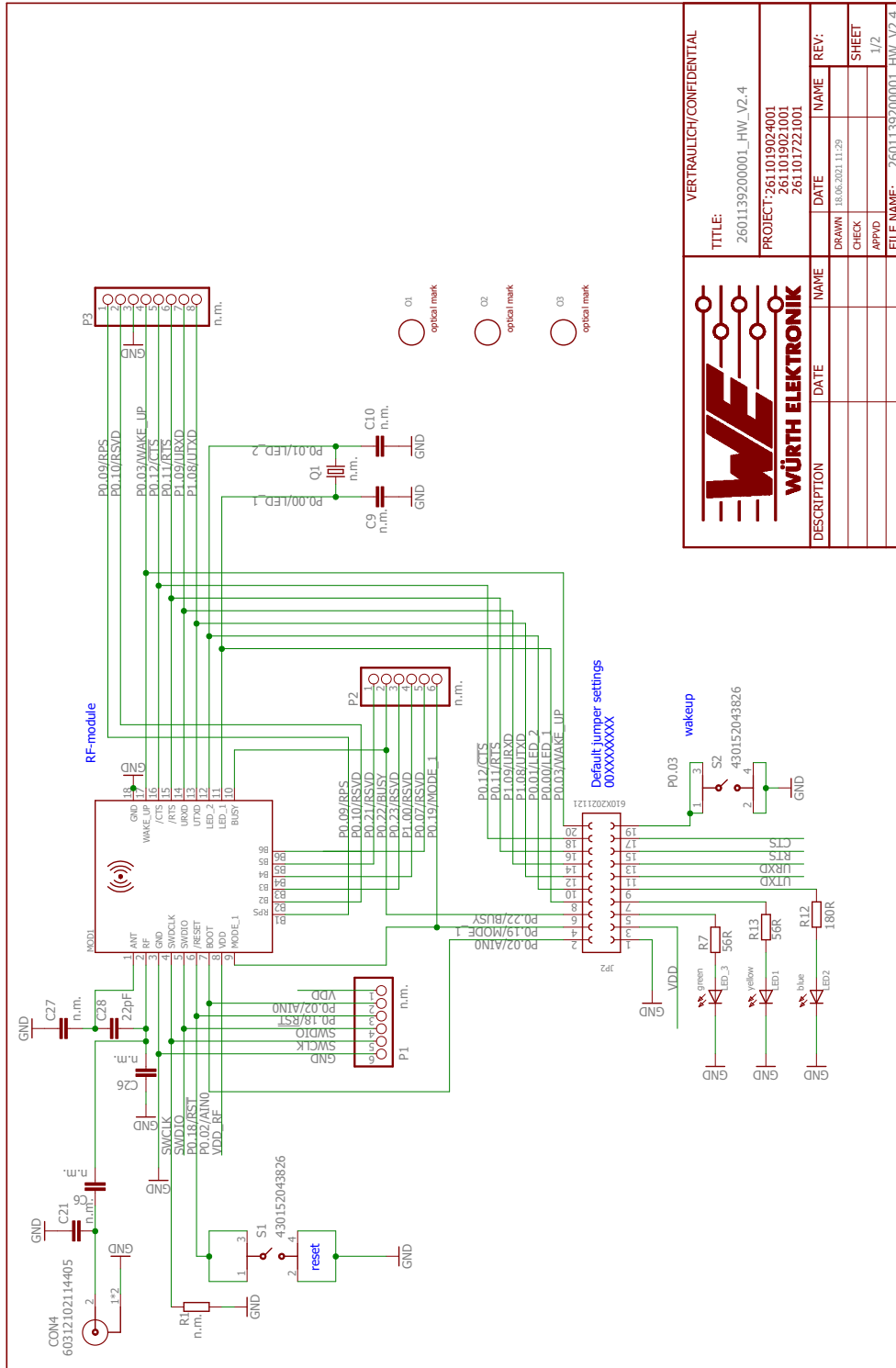

Figure 10: Reference design: Schematic page 1

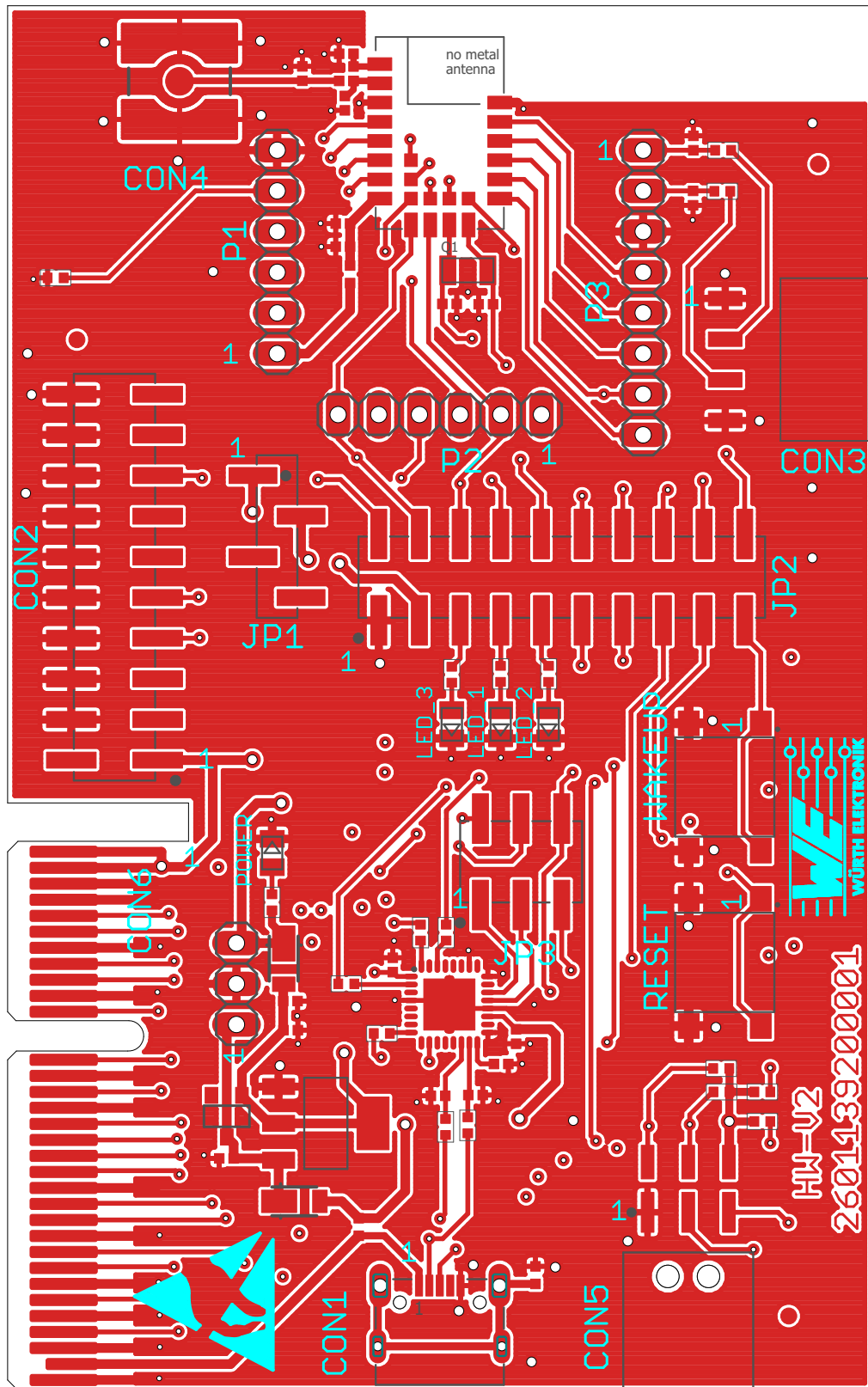

Figure 12: Reference design: Layout

13.2 Internal antenna radiation characteristics

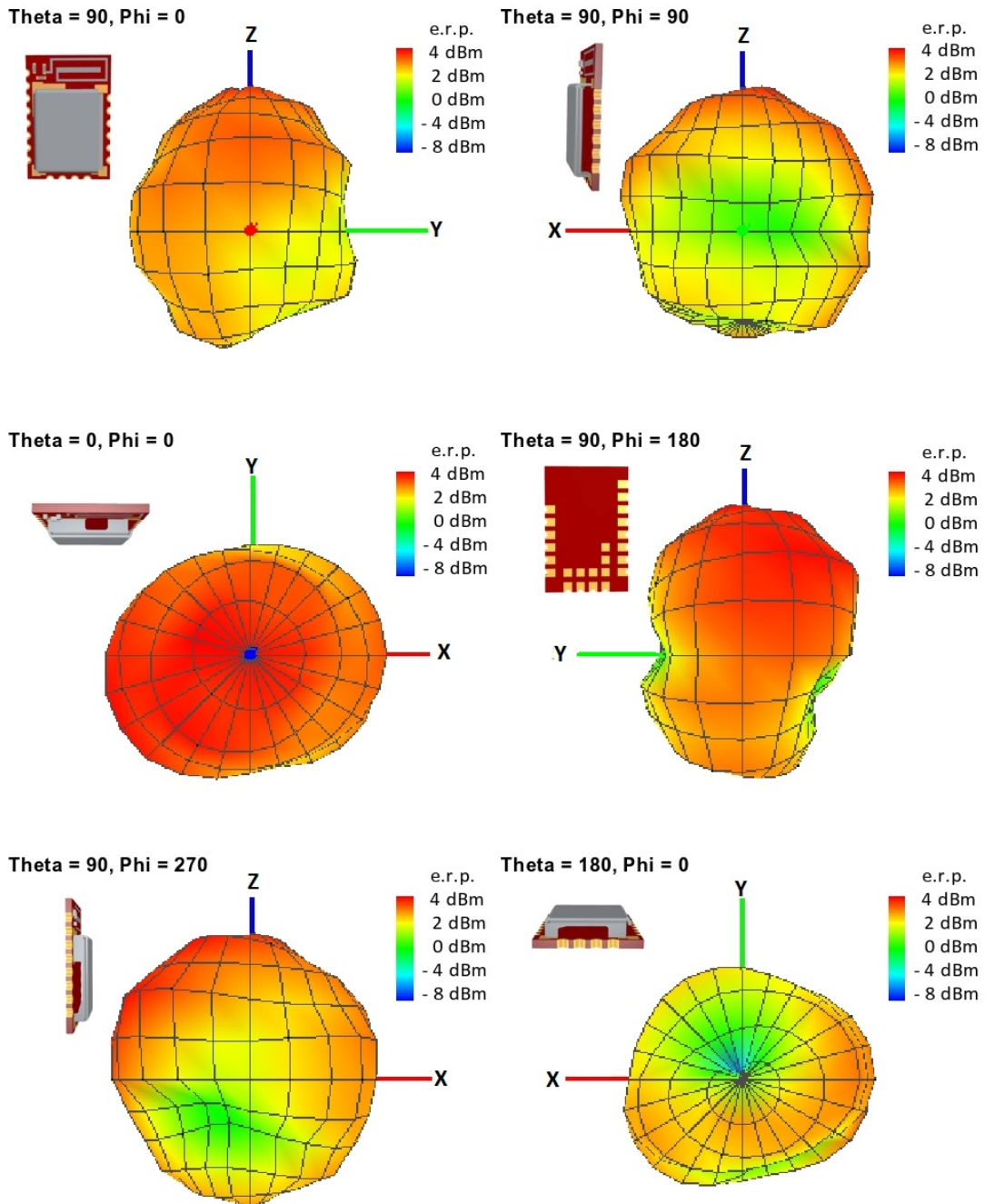

Figure 13: Antenna characteristic from integrated antenna measured on official EV-Board¹

¹Radiation characteristic shown is valid for the module on the EV-Board. It is important to be aware that size of groundplane and placement of module has influence on the radiation pattern.

13.3 Trace design

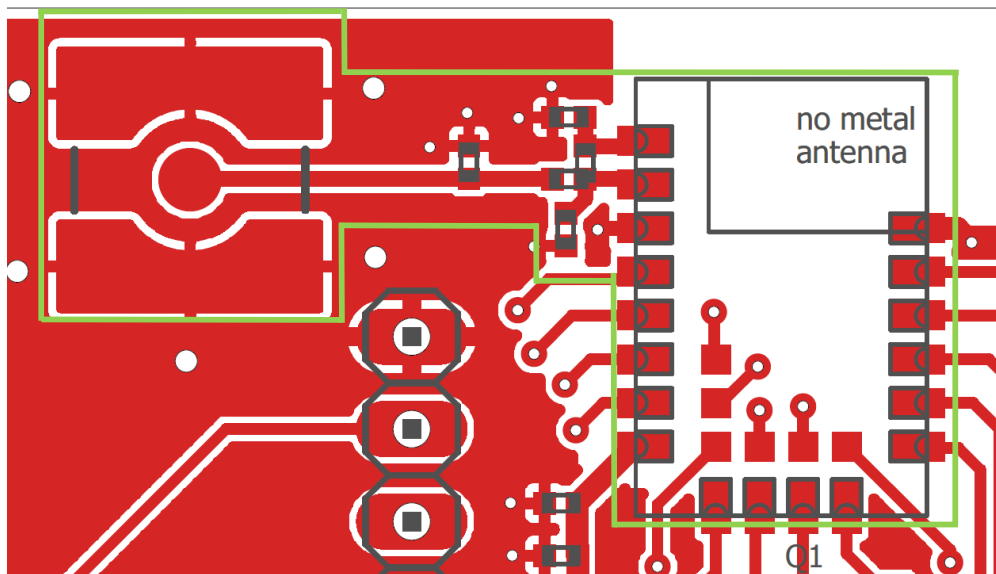

Figure 14: Trace design: Layout

Nr	Copper	Isolation
1	0.035mm	10mil
2	0.018mm	1mm
15	0.018mm	10mil
16	0.035mm	
Gesamt: 1.614mm		

Figure 15: Reference design: Stack-up

- Top layer is used for routing, filled with ground plane except area under the module and antenna free area.
- Second layer is filled with ground plane, except the antenna free area.
- Third layer is the supply layer, except antenna free area. Some routing is allowed, not dividing the supply layer in to many or too small parts.
- Bottom layer is used for routing and filled with ground except antenna free area.

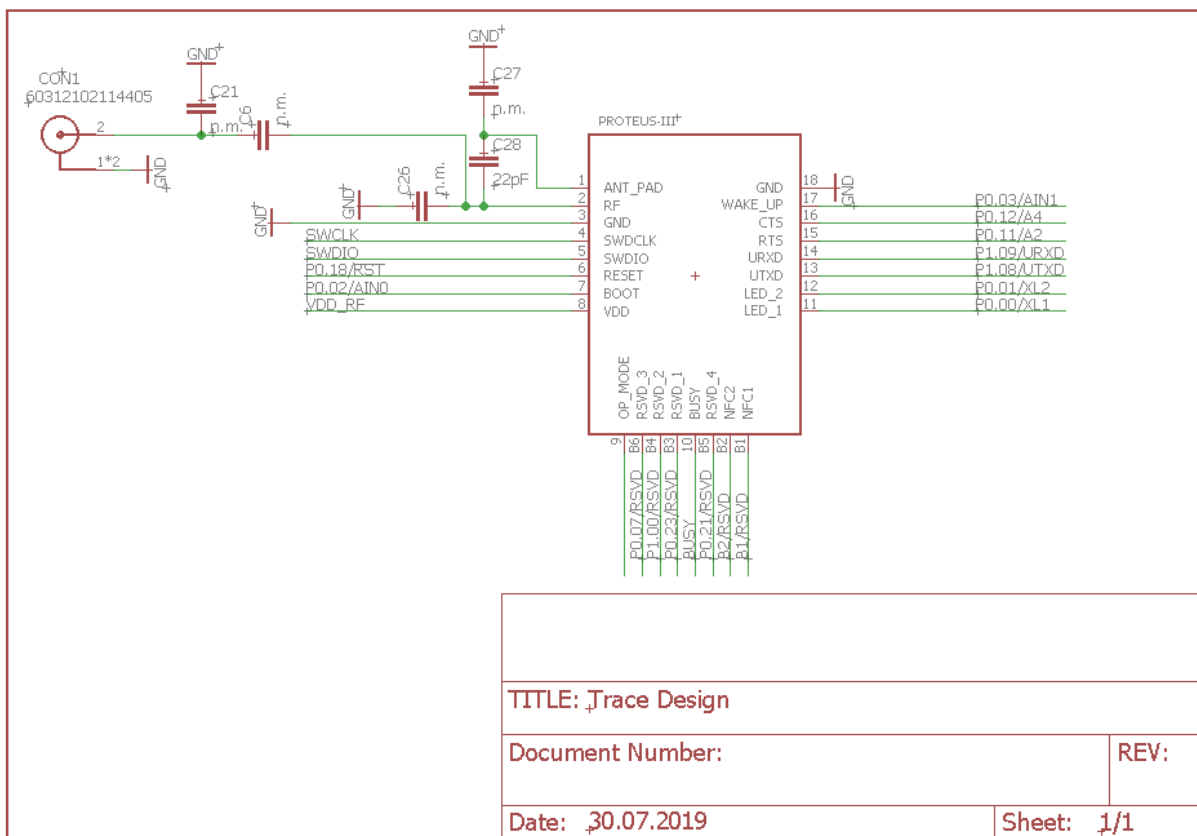

Figure 16: Trace design: Schematic

The RF pin of module can be coupled to on-board PCB antenna or an external antenna. Two variants of the Setebos-I are certified:

- For the on-board PCB antenna: 22 pF shall be assembled on C28.
 - If additional tuning is needed in the end application, C27 and C26 can be assembled.
 - The exact values of C27 and C26 shall be specified in the end application corresponding to the individual need.

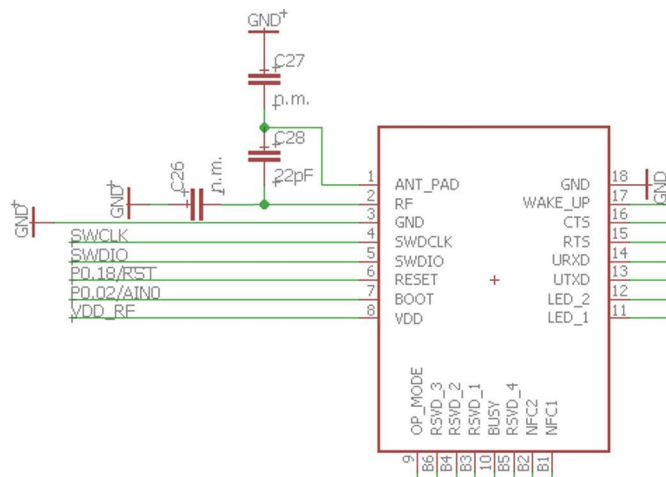

Figure 17: On-board PCB antenna

- For the external antenna: 22 pF shall be assembled on C6.
 - If additional tuning is needed in the end application, C21 and C26 can be assembled.
 - The exact values of C21 and C26 shall be specified in the end application corresponding to the individual need.

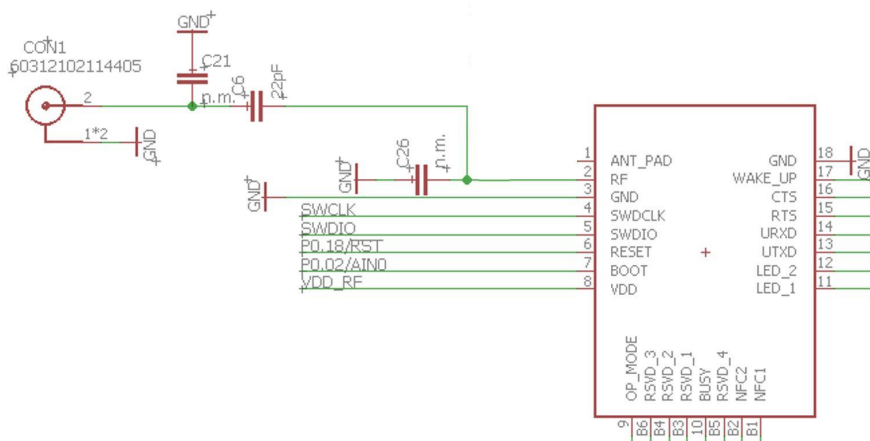

Figure 18: External antenna connection



To reference to the Würth Elektronik eiSos' FCC ID it is mandatory to use the trace design.

13.4 Battery powered systems

Radio modules require a certain type, range and quality of the power supply. When switching on the power (VCC) towards the module, a quick ramp-up of the VCC is required. During the radio module's operation the power must be stable, especially in scenarios of higher current consumption, like radio transmission operations with high power.

13.4.1 Recharging secondary cell batteries

The rise time of the VCC must be below 60 ms to make the chipset booting properly. In systems where a battery management circuit is charging secondary cell batteries after deep discharge, this requirement is not met.

To protect the application and radio module from malfunctioning in such a scenario, supervisor or reset ICs may help. These ICs can be used to enable the voltage regulator once the VCC is stable and above a defined voltage threshold. This ensures the required rapid ramp-up of the supply voltage and a minimum VCC level the module needs for reliable operation.

Besides of that, a second line of the reset IC may control the reset pin of the radio module, and thus only let the radio module boot-up after the voltage level is stable.

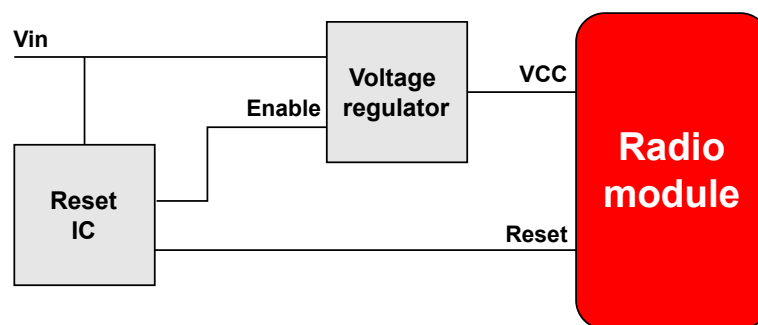

Figure 19: Reset IC

13.4.2 End device testing

In case of a battery operated end device, please test the following scenarios to ensure that the power supply is appropriate:

1. Data transmission with high output power and low battery voltage. Please check that the voltage drop will not lead to unwanted radio module behavior (reset or malfunctioning).
2. When discharging the battery, please check that the radio module is protected from voltage levels which are out of its specification.
3. When charging the battery from deep discharging, please check that the module's power is switched on as described in its specification.

14 Manufacturing information

14.1 Moisture sensitivity level

This wireless connectivity product is categorized as JEDEC Moisture Sensitivity Level 3 (MSL3), which requires special handling.

More information regarding the MSL requirements can be found in the IPC/JEDEC J-STD-020 standard on www.jedec.org.

More information about the handling, picking, shipping and the usage of moisture/reflow and/or process sensitive products can be found in the IPC/JEDEC J-STD-033 standard on www.jedec.org.

14.2 Soldering

14.2.1 Reflow soldering

Attention must be paid on the thickness of the solder resist between the host PCB top side and the modules bottom side. Only lead-free assembly is recommended according to JEDEC J-STD020.

Profile feature		Value
Preheat temperature, min	$T_{S \text{ Min}}$	150 °C
Preheat temperature, max	$T_{S \text{ Max}}$	200 °C
Preheat time from $T_{S \text{ Min}}$ to $T_{S \text{ Max}}$	t_S	60 - 120 s
Ramp-up rate (T_L to T_P)		3 °C/s max.
Liquidous temperature	T_L	217 °C
Time t_L maintained above T_L	t_L	60 - 150 s
Peak package body temperature	T_P	260 °C
Time within 5 °C of actual peak temperature	t_P	20 - 30 s
Ramp-down rate (T_P to T_L)		6 °C/s max.
Time 20 °C to T_P		8 min max.

Table 12: Classification reflow soldering profile, Note: refer to IPC/JEDEC J-STD-020E

It is recommended to solder this module on the last reflow cycle of the PCB. For solder paste use a LFM-48W or Indium based SAC 305 alloy (Sn 96.5 / Ag 3.0 / Cu 0.5 / Indium 8.9HF / Type 3 / 89 %) type 3 or higher.

The reflow profile must be adjusted based on the thermal mass of the entire populated PCB, heat transfer efficiency of the reflow oven and the specific type of solder paste used. Based on the specific process and PCB layout the optimal soldering profile must be adjusted and verified. Other soldering methods (e.g. vapor phase) have not been verified and have to be validated by the customer at their own risk. Rework is not recommended.

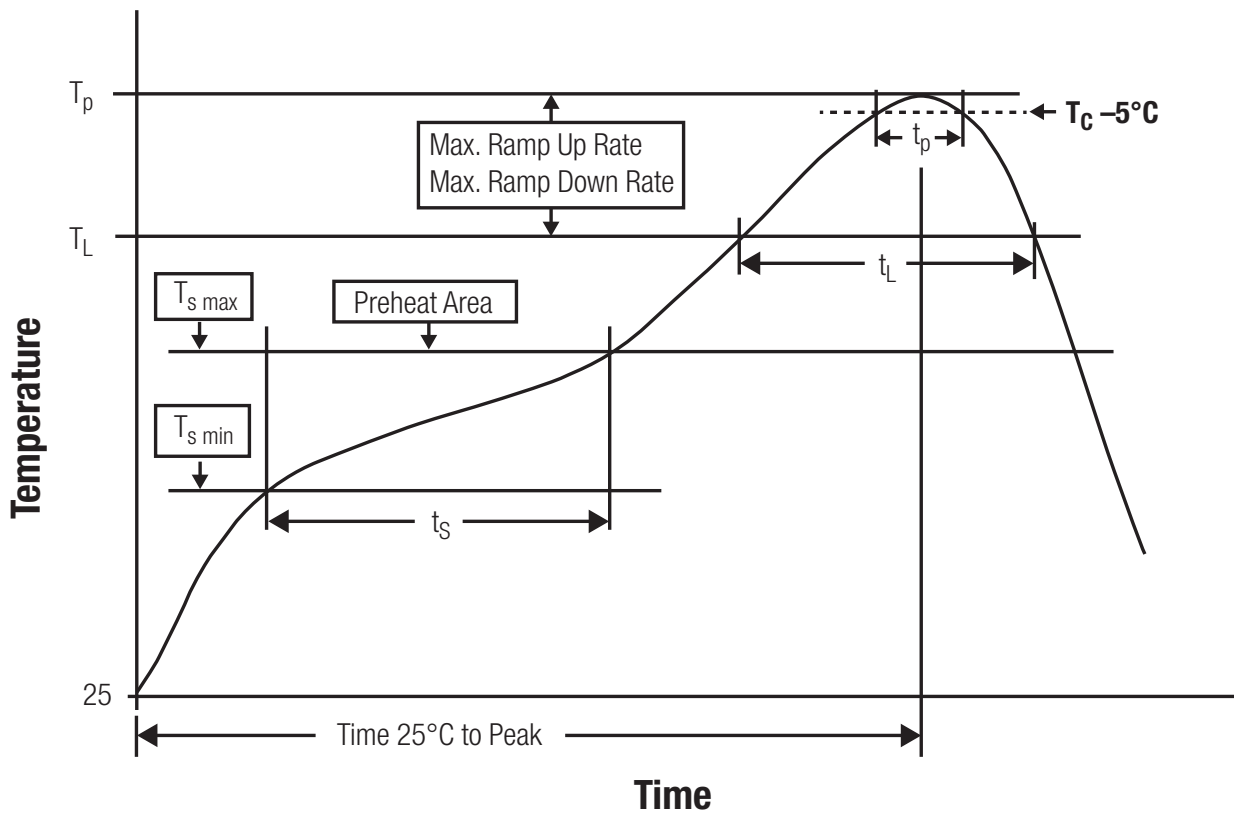

Figure 20: Reflow soldering profile

After reflow soldering, visually inspect the board to confirm proper alignment.

14.2.2 Cleaning

Do not clean the product. Any residue cannot be easily removed by washing. Use a "no clean" soldering paste and do not clean the board after soldering.

- Do not clean the product with water. Capillary effects can draw water into the gap between the host PCB and the module, absorbing water underneath it. If water is trapped inside, it may short-circuit adjoining pads. The water may also destroy the label and ink-jet printed text on it.
- Cleaning processes using alcohol or other organic solvents may draw solder flux residues into the housing, which won't be detected in a post-wash inspection. The solvent may also destroy the label and ink-jet printed text on it.
- Do not use ultrasonic cleaning as it will permanently damage the part, particularly the crystal oscillators.

14.2.3 Potting and coating

- If the product is potted in the customer application, the potting material might shrink or expand during and after hardening. Shrinking could lead to an incomplete seal, allowing contaminants into the component. Expansion could damage components. We recommend a manual inspection after potting to avoid these effects.
- Conformal coating or potting results in loss of warranty.
- The RF shield will not protect the part from low-viscosity coatings and potting. An undefined amount of coating and potting will enter inside the shielding.
- Conformal coating and potting will influence the parts of the radio front end and consequently influence the radio performance.
- Potting will influence the temperature behavior of the device. This might be critical for components with high power.

14.2.4 Other notations

- Do not attempt to improve the grounding by forming metal strips directly to the EMI covers or soldering on ground cables, as it may damage the part and will void the warranty.
- Always solder every pad to the host PCB even if some are unused, to improve the mechanical strength of the module.
- The part is sensitive to ultrasonic waves, as such do not use ultrasonic cleaning, welding or other processing. Any ultrasonic processing will void the warranty.

14.3 ESD handling

This product is highly sensitive to electrostatic discharge (ESD). As such, always use proper ESD precautions when handling. Make sure to handle the part properly throughout all stages of production, including on the host PCB where the module is installed. For ESD ratings, refer to the module series' maximum ESD section. For more information, refer to the relevant chapter 4. Failing to follow the aforementioned recommendations can result in severe damage to the part.

- The first contact point when handling the PCB is always between the local GND and the host PCB GND, unless there is a galvanic coupling between the local GND (for example work table) and the host PCB GND.
- Before assembling an antenna patch, connect the grounds.
- While handling the RF pin, avoid contact with any charged capacitors and be careful when contacting any materials that can develop charges (for example coaxial cable with around 50-80 pF/m, patch antenna with around 10 pF, soldering iron etc.)
- Do not touch any exposed area of the antenna to avoid electrostatic discharge. Do not let the antenna area be touched in a non ESD-safe manner.
- When soldering, use an ESD-safe soldering iron.

14.4 Safety recommendations

It is your duty to ensure that the product is allowed to be used in the destination country and within the required environment. Usage of the product can be dangerous and must be tested and verified by the end user. Be especially careful of:

- Use in areas with risk of explosion (for example oil refineries, gas stations).
- Use in areas such as airports, aircraft, hospitals, etc., where the product may interfere with other electronic components.

It is the customer's responsibility to ensure compliance with all applicable legal, regulatory and safety-related requirements as well as applicable environmental regulations. Disassembling the product is not allowed. Evidence of tampering will void the warranty.

- Compliance with the instructions in the product manual is recommended for correct product set-up.
- The product must be provided with a consolidated voltage source. The wiring must meet all applicable fire and security prevention standards.
- Handle with care. Avoid touching the pins as there could be ESD damage.

Be careful when working with any external components. When in doubt consult the technical documentation and relevant standards. Always use an antenna with the proper characteristics.



Würth Elektronik eiSos radio modules with high output power of up to 500 mW generate a large amount of heat while transmitting. The manufacturer of the end device must take care of potentially necessary actions for his application.

15 Product testing

15.1 Würth Elektronik eiSos in-house production tests

To achieve a high quality standard, Würth Elektronik eiSos follows a philosophy of supplying fully tested radio modules. At the end of the production process, every unit undergoes an optical inspection. Here the quality of soldering, edge castellation and edge milling is monitored.

If this has been passed, the radio modules are handed over to the automatic test equipment for the electrical characterization. This includes:

- Voltage and current tests to ensure proper electrical performance
- RF characteristics (frequency, spectrum, TX power) measurement and calibration
- Radio communication tests
- Firmware and serial number programming
- Host interface communication tests

The automated testing process is logged for internal quality control. The gained measurement data of each unit is analysed to detect defective parts and investigate the corresponding root cause. Defective radio modules are discarded, in order to guarantee a 100% failure-free delivery to customers.

15.2 EMS production tests

The rigorous in-series production testing ensures that EMS don't need to duplicate firmware tests or measurements. This streamlines the process and eliminates the need for additional testing over analogue and digital interfaces during device production. When it comes to device testing, the ideal focus should be on module assembly quality:

- All module pins are soldered properly on the base PCB
- There are no short circuits
- The mounting process did not damage the module
- The communication between host and radio module is working
- The antenna is connected properly

Simple "Go/No go" tests, like checking the RSSI value, give already a hint if the power supply and antenna have been connected properly.

In addition to such standard testing procedures, radio module integrators have the flexibility to perform additional dedicated tests to thoroughly evaluate the device. Specific tests they can consider are:

- Measure module current consumption in a specified operating state. Deviations from expected results (compared to a "Golden Device") can signal potential issues.

- Perform functional tests, including communication checks with the host controller and verification of interfaces.
- Assess fundamental RF characteristics (modulation accuracy, power levels, spectrum). Verify that the device meets expected performance standards.

16 Physical specifications

16.1 Dimensions

Dimensions
12 x 8 x 2 mm

Table 13: Dimensions

16.2 Weight

Weight
< 1 g

Table 14: Weight

16.3 Module drawing

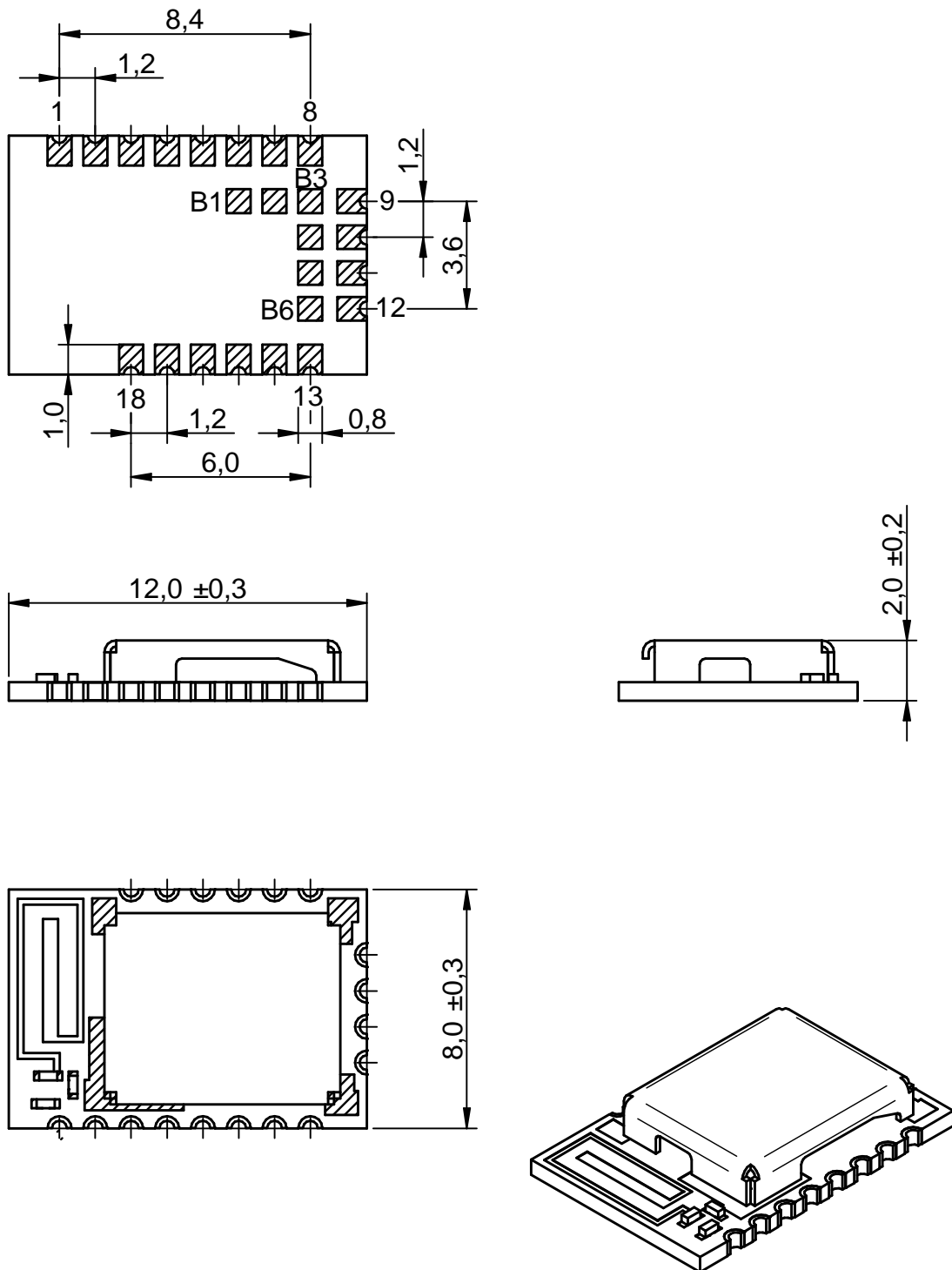

Figure 21: Module dimensions [mm]

17 Marking

17.1 Lot number

The 15 digit lot number is printed in numerical digits as well as in form of a machine readable bar code. It is divided into 5 blocks as shown in the following picture and can be translated according to the following table.

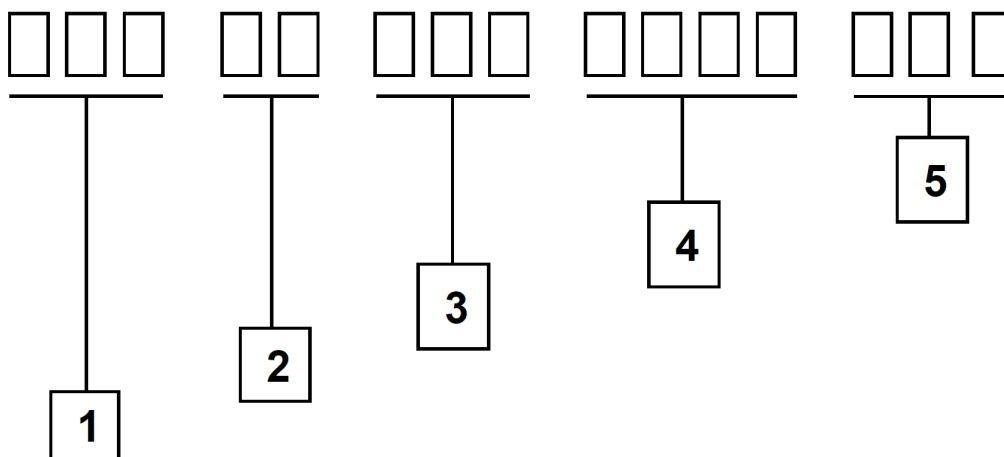

Figure 23: Lot number structure

Block	Information	Example(s)
1	eiSos internal, 3 digits	438
2	eiSos internal, 2 digits	01
3	Radio module hardware version, 3 digits	V2.4 = 024, V12.2 = 122
4	Date code, 4 digits	1703 = week 03 in year 2017, 1816 = week 16 in year 2018
5	Radio module firmware version, 3 digits	V3.2 = 302, V5.13 = 513

Table 15: Lot number details

As the user can perform a firmware update the printed lot number only shows the factory delivery state. The currently installed firmware can be requested from the module using the corresponding product specific command. The firmware version as well as the hardware version are restricted to show only major and minor version not the patch identifier. Block 5 is not applicable for products without firmware.

17.2 General labeling information

Labels of Würth Elektronik eiSos radio modules include several fields. Besides the manufacturer identification, the product's *WE* order code, serial number and certification information are placed on the label. In case of small labels, additional certification marks are placed on the label of the reel.

The information on the label are fixed. Only the serial number changes with each entity of the radio module. For Setebos-I the label is as follows:

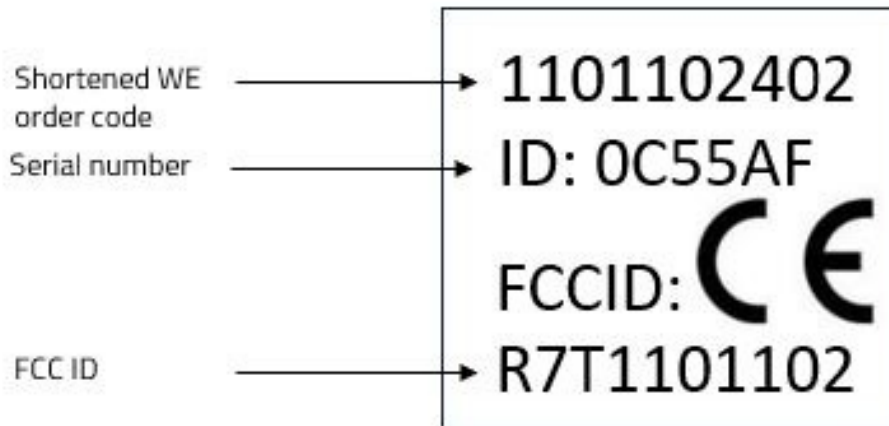

Figure 24: Label of the Setebos-I

18 Information for explosion protection

In case the end product should be used in explosion protection areas the following information can be used:

- The module itself is unfused.
- The maximum output power of the module is 6 dBm for external antenna and 4 dBm for internal antenna.
- The total amount of capacitance of all capacitors is 7.2 μF .
- The total amount of inductance of all inductors is 10.025 μH .
- A DC/DC regulator is included in the chip set and used to obtain low power functionality.

19 References

- [1] Würth Elektronik. User manual Proteus-III. <https://www.we-online.de/katalog/de/manual/2611011024000>.
- [2] Würth Elektronik. User manual Thyone-I. <https://www.we-online.de/katalog/de/manual/2611011021000>.

20 Regulatory compliance information

20.1 Important notice EU

The use of RF frequencies is limited by national regulations. The Setebos-I has been designed to comply with the RED directive 2014/53/EU of the European Union (EU).

The Setebos-I can be operated without notification and free of charge in the area of the European Union. However, according to the RED directive, restrictions (e.g. in terms of duty cycle or maximum allowed RF power) may apply.

Modifications (2014/53/EU article 3 (i))

Caution: Changes or modifications for this equipment not expressly approved by Würth Elektronik eiSos may void the CE conformity to operate this equipment.



Since the module itself is not fused the voltage supply shall be fed from a power source which is class PS2 according to EN 62368-1.

20.2 Important notice FCC

The use of RF frequencies is limited by national regulations. The Setebos-I has been designed to comply with the FCC Part 15.

The Setebos-I can be operated without notification and free of charge in the area of the United States of America. However, according to the FCC Part 15, restrictions (e.g. in terms of maximum allowed RF power and antenna) may apply.

20.3 Conformity assessment of the final product

The Setebos-I is a subassembly. It is designed to be embedded into other products (products incorporating the Setebos-I are henceforward referred to as "final products").

It is the responsibility of the manufacturer of the final product to ensure that the final product is in compliance with the essential requirements of the underlying national radio regulations.

The conformity assessment of the subassembly Setebos-I carried out by Würth Elektronik eiSos does not replace the required conformity assessment of the final product.

20.4 Exemption clause

Relevant regulation requirements are subject to change. Würth Elektronik eiSos does not guarantee the accuracy of the before mentioned information. Directives, technical standards, procedural descriptions and the like may be interpreted differently by the national authorities. Equally, the national laws and restrictions may vary with the country. In case of doubt or uncertainty, we recommend that you consult with the authorities or official certification organizations of the relevant countries. Würth Elektronik eiSos is exempt from any responsibilities or liabilities related to regulatory compliance.

Notwithstanding the above, Würth Elektronik eiSos makes no representations and warranties of any kind related to their accuracy, correctness, completeness and/or usability for customer applications. No responsibility is assumed for inaccuracies or incompleteness.

20.5 EU Declaration of conformity



EU DECLARATION OF CONFORMITY

Radio equipment: 2611011024020

The manufacturer: Würth Elektronik eiSos GmbH & Co. KG
Max-Eyth-Straße 1
74638 Waldenburg

This declaration of conformity is issued under the sole responsibility of the manufacturer.

Object of the declaration: 2611011024020

The object of the declaration described above is in conformity with the relevant Union harmonisation legislation Directive 2014/53/EU. Following harmonised norms or technical specifications have been applied:

EN 300 328 V2.2.2 (2019-07)
EN 301 489-1 V2.2.3 (2019-11)
EN 301 489-17 V3.3.1 (2024-09)
EN 62479 : 2010
EN 62368-1:2014 + AC:2015 +A11:2019
2011/65/EU with its amending Annex II EU 2015/863

i.A. G. Eslerdt

Trier, 13th of January 2026

Place and date of issue

20.6 RED-DA Cybersecurity statement

Cybersecurity as per articles 3.3d, 3.3e and 3.3f of the Radio Equipment Directive Delegated Act. The RED-DA mandates to comply to the EN 18031-1, 18031-2 and 18031-3 in order to fulfill the requirements of the cybersecurity chapters (d, e and f).

- EN 18031-1: Common security requirements for radio equipment - Part 1: Internet connected radio equipment
- EN 18031-2: Common security requirements for radio equipment - Part 2: Radio equipment processing data, namely internet connected radio equipment, childcare radio equipment, toys radio equipment and wearable radio equipment
- EN 18031-3: Common security requirements for radio equipment - Part 3: Internet connected radio equipment processing virtual money or monetary value

Requirements	Statement and conditions
(d) Radio equipment does not harm the network or its functioning nor misuses network resources, thereby causing an unacceptable degradation of service	<p>"Not applicable": The product is not capable itself to communicate over the internet. The product is only able to communicate via the following protocols and interfaces. None of the protocols contained in the product are "internet-connectable".</p> <p>Radio communication protocols: This Bluetooth (2.1, 4.x, 5.x, 6.x) product does not support or include the "Internet Protocol Support Profile". Bluetooth is a set of radio standards (e.g. Bluetooth Classic, Bluetooth Low Energy, Bluetooth MESH, Bluetooth LE Audio, ...) maintained by the Bluetooth SIG.</p> <p>WE-ProWare is Würth Elektronik eiSos industry approved proprietary set of radio protocol combining our own MAC and PHY layers. The WE-ProWare protocol is payload agnostic.</p> <p>Host Interface, wired: The host interface of the product does not support internet connectivity. UART is used as a wired communication and control channel towards the customers host.</p>
(e) Radio equipment incorporates safeguards to ensure that the personal data and privacy of the user and of the subscriber are protected	<p>"Not applicable": The product is not internet connected. The product does not pose a risk to the users or subscribers privacy, as it does not store or process any personal data.</p>

<p>(f) Radio equipment supports certain features ensuring protection from fraud</p>	<p>"Not applicable": The product is not internet connected. The product does not pose a risk of fraud because it does not store or process financial data or enables financial transactions.</p>
---	--

20.7 UK Declaration of conformity



DECLARATION OF CONFORMITY

Product:	Setebos-I Bluetooth 5.1 combined Radio Module
Model/type:	2611011024020
The manufacturer:	Würth Elektronik eiSos GmbH & Co. KG Max-Eyth-Straße 1 74638 Waldenburg
The importer:	Würth Electronics UK Limited 8th Floor, 8 Exchange Quay, Salford Quays Manchester GB - M5 3EJ

This declaration of conformity is issued under the sole responsibility of the manufacturer.

Object of the declaration: 2611011024020

The object of the declaration described above is in conformity with the relevant UK Statutory Instruments: The Radio Equipment Regulations 2017 (S.I. 2017 No. 1206) & The Restriction of the Use of Certain Hazardous Substances in Electrical and Electronic Equipment Regulations 2012 (S.I. 2012 No.3032) .

References to the relevant designated standards used or references to the other technical specifications in relation to which conformity is declared:

EN 300 328 V2.2.2 (2019-07)
EN 301 489-1 V2.2.3 (2019-11)
EN 301 489-17 V3.2.4 (2020-09)
EN 62479 : 2010
EN 62368-1:2014 + AC:2015 +A11:2019

i.A. G. Eckhardt

Gudrun Eckhardt, Teamleader Hardware Development, Trier, 28th of April 2023
Name, Function, Place and date of issue

20.8 FCC Compliance Statement (US)

FCC ID: R7T1101102

This device complies with Part 15 of the FCC Rules.

Operation is subject to the following two conditions:

- (1) this device may not cause harmful interference, and
(2) this device must accept any interference received, including interference that may cause undesired operation.
(FCC 15.19)

Modifications (FCC 15.21)

Caution: Changes or modifications for this equipment not expressly approved by Würth Elektronik eiSos may void the FCC authorization to operate this equipment.

20.8.1 FCC certificate

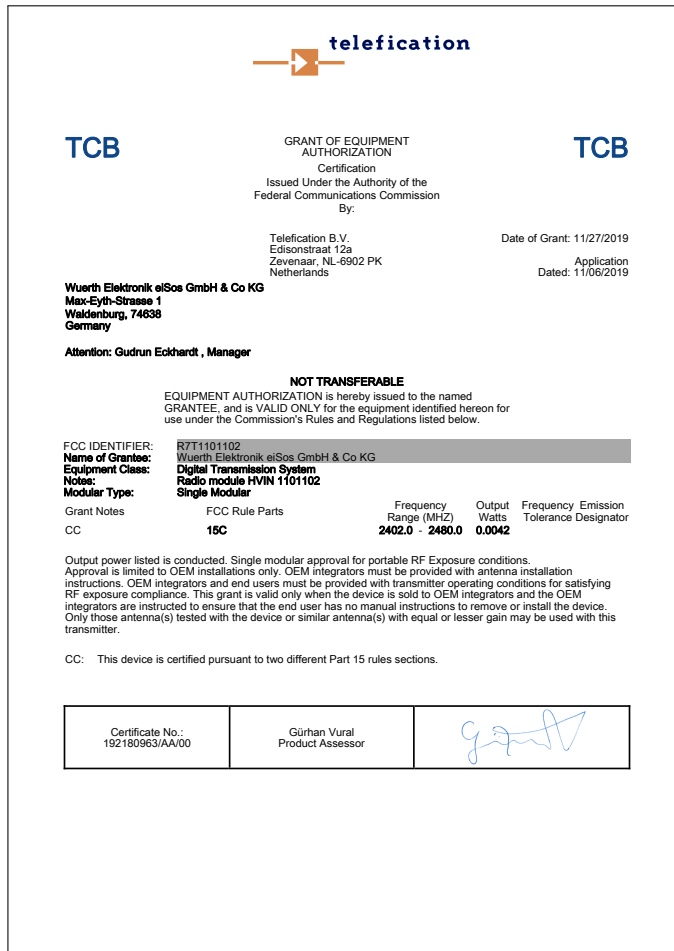

Figure 25: FCC certificate

20.9 IC Compliance Statement (Canada)

Certification Number: 5136A-1101102

HVIN: 1101102

This device complies with Industry Canada licence-exempt RSS standard(s). Operation is subject to the following two conditions: (1) this device may not cause harmful interference, and (2) this device must accept any interference received, including interference that may cause undesired operation.

Le présent appareil est conforme aux CNR d'Industrie Canada applicables aux appareils radio exempts de licence. L'exploitation est autorisée aux deux conditions suivantes : (1) l'appareil ne doit pas produire de brouillage, et (2) l'utilisateur de l'appareil doit accepter tout brouillage radioélectrique subi, même si le brouillage est susceptible d'en compromettre le fonctionnement.

20.9.1 IC certificate

telefication bv
The Netherlands
Chamber of Commerce
51565536
www.telefication.com



telefication

TECHNICAL ACCEPTANCE CERTIFICATE	CERTIFICAT D'ACCEPTABILITÉ TECHNIQUE				
CERTIFICATION No. No. DE CERTIFICATION	5136A-1101102				
TELEFICATION No. No. DE TELEFICATION	192170345/AA/00				
TEST SITE No. No. DE LABORATOIRE	3699A				
ISSUED TO DÉLIVRÉ À					
TYPE OF EQUIPMENT GENRE DE MATÉRIEL	SPREAD SPECTRUM DEVICE (2400-2483.5 MHz)				
TRADE NAME AND MODEL MARQUE ET MODÈLE	Würth Elektronik eiSos GmbH & Co. KG / 1101102				
CERTIFIED TO CERTIFIÉ SELON LE	<table style="width: 100%; border-collapse: collapse;"> <tr> <td style="width: 30%;">SPECIFICATION CAHIER DES CHARGES</td> <td style="width: 20%;">RSS-102 RSS-247</td> <td style="width: 20%;">ISSUE ÉDITION</td> <td style="width: 30%; text-align: right;">5 2</td> </tr> </table>	SPECIFICATION CAHIER DES CHARGES	RSS-102 RSS-247	ISSUE ÉDITION	5 2
SPECIFICATION CAHIER DES CHARGES	RSS-102 RSS-247	ISSUE ÉDITION	5 2		

Certification of equipment means only that the equipment has met the requirements of the above-noted specification. Licence applications, where applicable to use certified equipment, are acted on accordingly by the ISDE issuing office and will depend on the existing radio environment, service and location of operation. This certificate is issued on condition that the holder complies and will continue to comply with the requirements and procedures issued by ISDE. The equipment for which this certificate is issued shall not be manufactured, imported, distributed, leased, offered for sale or sold unless the equipment complies with the applicable technical specifications and procedures issued by ISDE.

La certification du matériel signifie seulement que le matériel a satisfait aux exigences de la norme indiquée ci-dessus. Les demandes de licences nécessaires pour l'utilisation du matériel certifié sont traitées en conséquence par le bureau de délivrance d'ISDE et dépendent des conditions radio ambiantes, du service et de l'emplacement d'exploitation. Le présent certificat est délivré à la condition que le titulaire satisfasse et continue de satisfaire aux exigences et aux procédures d'ISDE. Le matériel à l'égard duquel le présent certificat est délivré ne doit pas être fabriqué, importé, distribué, loué, mis en vente ou vendu à moins d'être conforme aux procédures et aux spécifications techniques applicables publiées par ISDE.

ISSUED BY TELEFICATION BV (NL0001), RECOGNIZED CERTIFICATION BODY BY INNOVATION, SCIENCE AND ECONOMIC DEVELOPMENT CANADA
DÉLIVRÉ PAR TELEFICATION BV (NL0001), ORGANISME DE CERTIFICATION RECONNU PAR INNOVATION, SCIENCES ET DÉVELOPPEMENT ÉCONOMIQUE CANADA

*I hereby attest that the subject equipment was tested and found in compliance with the above-noted specification.
J'atteste, par la présente, que le matériel a fait l'objet d'essai et a été jugé conforme à la spécification ci-dessus*

DATE 02 Dec 2019 BY

This certificate has one annex.

Gürhan Vural
Product Assessor

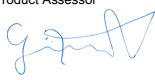





laboratory



certification



approvals

Figure 26: IC certificate

20.10 FCC and IC requirements to OEM integrators

This module has been granted modular approval. OEM integrators for host products may use the module in their final products without additional FCC/IC (Industry Canada) certification if they meet the following conditions. Otherwise, additional FCC/IC approvals must be obtained. The host product with the module installed must be evaluated for simultaneous transmission requirements.

- The users manual for the host product must clearly indicate the operating requirements and conditions that must be observed to ensure compliance with current FCC/IC RF exposure guidelines.
- A label must be affixed to the outside of the host product with the following statements:
This device contains FCC ID: R7T1101102
This equipment contains equipment certified under IC ID: 5136A-1101102
- The final host / module combination may also need to be evaluated against the FCC Part 15B criteria for unintentional radiators in order to be properly authorized for operation as a Part 15 digital device.
- If the final host / module combination is intended for use as a portable device (see classifications below) the host manufacturer is responsible for separate approvals for the SAR requirements from FCC Part 2.1093 and RSS-102.

OEM requirements:

The OEM must ensure that the following conditions are met.

- The Setebos-I will be used at a distance of at least 10 mm to the human body.
- End users of products, which contain the module, must not have the ability to alter the firmware that governs the operation of the module. The agency grant is valid only when the module is incorporated into a final product by OEM integrators.
- The end-user must not be provided with instructions to remove, adjust or install the module.
- The Original Equipment Manufacturer (OEM) must ensure that FCC labeling requirements are met. This includes a clearly visible label on the outside of the final product. Attaching a label to a removable portion of the final product, such as a battery cover, is not permitted.
- The label must include the following text:
Contains FCC ID: R7T1101102
The enclosed device complies with Part 15 of the FCC Rules. Operation is subject to the following two conditions:
(i.) this device may not cause harmful interference and
(ii.) this device must accept any interference received, including interference that may cause undesired operation.

When the device is so small or for such use that it is not practicable to place the statement

above on it, the information required by this paragraph shall be placed in a prominent location in the instruction manual or pamphlet supplied to the user or, alternatively, shall be placed on the container in which the device is marketed. However, the FCC identifier or the unique identifier, as appropriate, must be displayed on the device.

- The user manual for the end product must also contain the text given above.
 - Changes or modifications not expressly approved could void the user's authority to operate the equipment.
 - The OEM must ensure that timing requirements according to 47 CFR 15.231(a-c) are met.
 - The module must be used with only the following approved antenna(s).

20.10.1 Pre-certified antennas

The Setebos-I is pre-certified with the following antennas.

Product	Certified antenna
Setebos-I (2611011024020)	PCB antenna included in the Setebos-I

20.11 ETA-WPC (India)

Registration No: ETA-SD-20230302019 Date: 06-04-2023

The Setebos-I complies with the provisions on the Equipment Type Approval WPC Wing for India.

20.11.1 ETA-WPC certificate

 सत्यमेव जयते	Government of India Ministry of Communications Department of Telecommunications WPC Wing Sanchar Bhawan, New Delhi-110001.		
<p>[Generation of Equipment Type Approval (ETA) through self-declaration issued under O.M. No. ETA-WPC /Policy/2018-19 dated 26 February, 2019].</p>			
<p>THIS ETA IS ISSUED FOR A SINGLE MODEL WITH MODEL NAME <u>Setebos-I</u></p>			
Registration No:	ETA-SD-20230302019	Date:	06-04-2023
<p>D). Details of Applicant and Parameters of Equipment:</p>			
1.	Name & Address of the first Applicant. (Indian Manufacturer/ Authorised Indian representative for foreign manufacturer)	WURTH ELECTRONICS SERVICES INDIA PRIVATE LIMITED, Ground and 1st Floor, No. 3, Prestige Sterling Square, Madras Bank Road, Next to Airlines Hotel, Bangalore, Bengaluru Bangalore Urban, Karnataka, 560001, Bangalore Urban,KARNATAKA,560001	
2.	Equipment category	Bluetooth Low Energy/ WE-ProWare Module	
3.	Make	Wurth Elektronik eiSos GmbH & Co. KG,Germany	
4.	Model	Setebos-I	
5.	Frequency range(s) of Equipment	1. 2402-2480 MHz	
6.	Max output power/Field strength/PSD	1. E.I.R.P. (dBm). 4	

1/2

Figure 27: ETA-WPC certificate page 1

7.	Applicable Gazette Notification(s)	1. 45 (E) Dated 28-01-2005	
8.	RF Test Report details:-		
	Name&Address /Country of accredited laboratory issuing the RF test report	Accreditation Certificate Reference/Number	Test Report No. and Date
	7layers GmbH & Borsigstrasse 11 40880 Ratingen Germany	D-PL-12140-01-03	MDE_WUERTH_1901_RADIO01 & 15-10-2019

II). Terms and Conditions

- (i). This certificate will not be valid in case any change in the above parameters and not conforming to the Gazette Notification mentioned in sl.no 7 above.
- (ii). Use of such equipment has been exempted from licensing requirement vide Gazette Notification mentioned in sl. no. 7, on Non-interference,Non-protectionand sharing (non-exclusive) basis.
- (iii). Use of such equipment in case not conforming to above notification will require a specific wireless operating license, as applicable from this Ministry.
- (iv). Field units of WPC Wing reserve the right for sample check/audit carried out for the purpose of RF analysis/spectrum monitoring in view to avoid interference to other wireless users and ensure compliance of technical parameters mentioned in sl no. 5,6&7.
- (v). This certificate is valid only for equipment which are exempted from import licensing requirements as per the Import Policy of DGFT and for import of such device, a self-declaration based, system generated (Saralsanchar) Import undertaking/ permission is required.
- (vi). The applicant is liable for prosecution under Indian Law in case of any wrong declaration/ submission of ingenuine RF test report(s) for issue of ETA through Self-Declaration.

Note:

- 1. Once ETA through self-declaration is generated for a model, subsequently it may be utilized by other person(s) for import/usage purpose in India.
- 2. The importers of above model shall comply with other import related requirements, if any, with Customs.

This is Self-generated certificate. Hence, no signature is required. It may be downloaded/verified from the website <https://saralsanchar.gov.in>.

Figure 28: ETA-WPC certificate page 2

21 Important notes

The following conditions apply to all goods within the wireless connectivity and sensors product range of Würth Elektronik eiSos GmbH & Co. KG:

General customer responsibility

Some goods within the product range of Würth Elektronik eiSos GmbH & Co. KG contain statements regarding general suitability for certain application areas. These statements about suitability are based on our knowledge and experience of typical requirements concerning the areas, serve as general guidance and cannot be estimated as binding statements about the suitability for a customer application. The responsibility for the applicability and use in a particular customer design is always solely within the authority of the customer. Due to this fact, it is up to the customer to evaluate, where appropriate to investigate and to decide whether the device with the specific product characteristics described in the product specification is valid and suitable for the respective customer application or not. Accordingly, the customer is cautioned to verify that the documentation is current before placing orders.

Customer responsibility related to specific, in particular safety-relevant applications

It has to be clearly pointed out that the possibility of a malfunction of electronic components or failure before the end of the usual lifetime cannot be completely eliminated in the current state of the art, even if the products are operated within the range of the specifications. The same statement is valid for all software source code and firmware parts contained in or used with or for products in the wireless connectivity and sensor product range of Würth Elektronik eiSos GmbH & Co. KG. In certain customer applications requiring a high level of safety and especially in customer applications in which the malfunction or failure of an electronic component could endanger human life or health, it must be ensured by most advanced technological aid of suitable design of the customer application that no injury or damage is caused to third parties in the event of malfunction or failure of an electronic component.

Best care and attention

Any product-specific data sheets, manuals, application notes, PCNs, warnings and cautions must be strictly observed in the most recent versions and matching to the products revisions. These documents can be downloaded from the product specific sections on the wireless connectivity and sensors homepage.

Customer support for product specifications

Some products within the product range may contain substances, which are subject to restrictions in certain jurisdictions in order to serve specific technical requirements. Necessary information is available on request. In this case, the Business Development Engineer (BDM) or the internal sales person in charge should be contacted who will be happy to support in this matter.

Product improvements

Due to constant product improvement, product specifications may change from time to time. As a standard reporting procedure of the Product Change Notification (PCN) according to the JEDEC-Standard, we inform about major changes. In case of further queries regarding the PCN, the Business Development Engineer (BDM), the internal sales person or the technical support team in charge should be contacted. The basic responsibility of the customer as per section 21 and 21 remains unaffected.

All software like "wireless connectivity SDK", "Sensor SDK" or other source codes as well as all PC software tools are not subject to the Product Change Notification information process.

Product life cycle

Due to technical progress and economical evaluation, we also reserve the right to discontinue production and delivery of products. As a standard reporting procedure of the Product Termination Notification (PTN) according to the JEDEC-Standard we will inform at an early stage about inevitable product discontinuance. According to this, we cannot ensure that all products within our product range will always be available. Therefore, it needs to be verified with the Business Development Engineer (BDM) or the internal sales person in charge about the current product availability expectancy before or when the product for application design-in disposal is considered. The approach named above does not apply in the case of individual agreements deviating from the foregoing for customer-specific products.

Property rights

All the rights for contractual products produced by Würth Elektronik eiSos GmbH & Co. KG on the basis of ideas, development contracts as well as models or templates that are subject to copyright, patent or commercial protection supplied to the customer will remain with Würth Elektronik eiSos GmbH & Co. KG. Würth Elektronik eiSos GmbH & Co. KG does not warrant or represent that any license, either expressed or implied, is granted under any patent right, copyright, mask work right, or other intellectual property right relating to any combination, application, or process in which Würth Elektronik eiSos GmbH & Co. KG components or services are used.

General terms and conditions

Unless otherwise agreed in individual contracts, all orders are subject to the current version of the "General Terms and Conditions of Würth Elektronik eiSos Group", last version available at www.we-online.com.

22 Legal notice

Exclusion of liability

Würth Elektronik eiSos GmbH & Co. KG considers the information in this document to be correct at the time of publication. However, Würth Elektronik eiSos GmbH & Co. KG reserves the right to modify the information such as technical specifications or functions of its products or discontinue the production of these products or the support of one of these products without any written announcement or notification to customers. The customer must make sure that the information used corresponds to the latest published information. Würth Elektronik eiSos GmbH & Co. KG does not assume any liability for the use of its products. Würth Elektronik eiSos GmbH & Co. KG does not grant licenses for its patent rights or for any other of its intellectual property rights or third-party rights.

Notwithstanding anything above, Würth Elektronik eiSos GmbH & Co. KG makes no representations and/or warranties of any kind for the

provided information related to their accuracy, correctness, completeness, usage of the products and/or usability for customer applications. Information published by Würth Elektronik eiSos GmbH & Co. KG regarding third-party products or services does not constitute a license to use such products or services or a warranty or endorsement thereof.

Suitability in customer applications

The customer bears the responsibility for compliance of systems or units, in which Würth Elektronik eiSos GmbH & Co. KG products are integrated, with applicable legal regulations. Customer acknowledges and agrees that it is solely responsible for compliance with all legal, regulatory and safety-related requirements concerning its products, and any use of Würth Elektronik eiSos GmbH & Co. KG components in its applications, notwithstanding any applications-related information or support that may be provided by Würth Elektronik eiSos GmbH & Co. KG. Customer represents and agrees that it has all the necessary expertise to create and implement safeguards which anticipate dangerous consequences of failures, monitor failures and their consequences lessen the likelihood of failures that might cause harm and take appropriate remedial actions. The customer will fully indemnify Würth Elektronik eiSos GmbH & Co. KG and its representatives against any damages arising out of the use of any Würth Elektronik eiSos GmbH & Co. KG components in safety-critical applications.

Trademarks

AMBER wireless is a registered trademark of Würth Elektronik eiSos GmbH & Co. KG. All other trademarks, registered trademarks, and product names are the exclusive property of the respective owners.

Usage restriction

Würth Elektronik eiSos GmbH & Co. KG products have been designed and developed for usage in general electronic equipment only. This product is not authorized for use in equipment where a higher safety standard and reliability standard is especially required or where a failure of the product is reasonably expected to cause severe personal injury or death, unless the parties have executed an agreement specifically governing such use. Moreover, Würth Elektronik eiSos GmbH & Co. KG products are neither designed nor intended for use in areas such as military, aerospace, aviation, nuclear control, submarine, transportation (automotive control, train control, ship control), transportation signal, disaster prevention, medical, public information network etc. Würth Elektronik eiSos GmbH & Co. KG must be informed about the intent of such usage before the design-in stage. In addition, sufficient reliability evaluation checks for safety must be performed on every electronic component, which is used in electrical circuits that require high safety and reliability function or performance. By using Würth Elektronik eiSos GmbH & Co. KG products, the customer agrees to these terms and conditions.

23 License terms

These License terms will take effect upon the purchase and usage of the Würth Elektronik eiSos GmbH & Co. KG wireless connectivity products. You hereby agree that these license terms are applicable to the product and the incorporated software, firmware and source codes (collectively, "Software") made available by Würth Elektronik eiSos in any form, including but not limited to binary, executable or source code form. The software included in any Würth Elektronik eiSos wireless connectivity product is purchased to you on the condition that you accept the terms and conditions of these license terms. You agree to comply with all provisions under these license terms.

Limited license

Würth Elektronik eiSos hereby grants you a limited, non-exclusive, non-transferable and royalty-free license to use the software and under the conditions that will be set forth in these license terms. You are free to use the provided software only in connection with one of the products from Würth Elektronik eiSos to the extent described in these license terms. You are entitled to change or alter the source code for the sole purpose of creating an application embedding the Würth Elektronik eiSos wireless connectivity product. The transfer of the source code to third parties is allowed to the sole extent that the source code is used by such third parties in connection with our product or another hardware provided by Würth Elektronik eiSos under strict adherence of these license terms. Würth Elektronik eiSos will not assume any liability for the usage of the incorporated software and the source code. You are not entitled to transfer the source code in any form to third parties without prior written consent of Würth Elektronik eiSos.

You are not allowed to reproduce, translate, reverse engineer, decompile, disassemble or create derivative works of the incorporated software and the source code in whole or in part. No more extensive rights to use and exploit the products are granted to you.

Usage and obligations

The responsibility for the applicability and use of the Würth Elektronik eiSos wireless connectivity product with the incorporated firmware in a particular customer design is always solely within the authority of the customer. Due to this fact, it is up to you to evaluate and investigate, where appropriate, and to decide whether the device with the specific product characteristics described in the product specification is valid and suitable for your respective application or not.

You are responsible for using the Würth Elektronik eiSos wireless connectivity product with the incorporated firmware in compliance with all applicable product liability and product safety laws. You acknowledge to minimize the risk of loss and harm to individuals and bear the risk for failure leading to personal injury or death due to your usage of the product.

Würth Elektronik eiSos' products with the incorporated firmware are not authorized for use in safety-critical applications, or where a failure of the product is reasonably expected to cause severe personal injury or death. Moreover, Würth Elektronik eiSos' products with the incorporated firmware are neither designed nor intended for use in areas such as military, aerospace, aviation, nuclear control, submarine, transportation (automotive control, train control, ship control), transportation signal, disaster prevention, medical, public information network etc. You shall inform Würth Elektronik eiSos about the intent of such usage before design-in stage. In certain customer applications requiring a very high level of safety and in which the malfunction or failure of an electronic component could endanger human life or health, you must ensure to have all necessary expertise in the safety and regulatory ramifications of your applications. You acknowledge and agree that you are solely responsible for all legal, regulatory and safety-related requirements concerning your products and any use of Würth Elektronik eiSos' products with the incorporated firmware in such safety-critical applications, notwithstanding any applications-related information or support that may be provided by Würth Elektronik eiSos. **YOU SHALL INDEMNIFY WÜRTH ELEKTRONIK EISOS AGAINST ANY DAMAGES ARISING OUT OF THE USE OF WÜRTH ELEKTRONIK EISOS' PRODUCTS WITH THE INCORPORATED FIRMWARE IN SUCH SAFETY-CRITICAL APPLICATIONS.**

Ownership

The incorporated firmware created by Würth Elektronik eiSos is and will remain the exclusive property of Würth Elektronik eiSos.

Firmware update(s)

You have the opportunity to request the current and actual firmware for a bought wireless connectivity product within the time of warranty. However, Würth Elektronik eiSos has no obligation to update a modules firmware in their production facilities, but can offer this as a service on request. The upload of firmware updates falls within your responsibility, e.g. via ACC or another software for firmware updates. Firmware updates will not be communicated automatically. It is within your responsibility to check the current version of a firmware in the latest version of the product manual on our website. The revision table in the product manual provides all necessary information about firmware updates. There is no right to be provided with binary files, so called "firmware images", those could be flashed through JTAG, SWD, Spi-Bi-Wire, SPI or similar interfaces.

Disclaimer of warranty

THE FIRMWARE IS PROVIDED "AS IS". YOU ACKNOWLEDGE THAT WÜRTH ELEKTRONIK EISOS MAKES NO REPRESENTATIONS AND WARRANTIES OF ANY KIND RELATED TO, BUT NOT LIMITED TO THE NON-INFRINGEMENT OF THIRD PARTIES' INTELLECTUAL PROPERTY RIGHTS OR THE MERCHANTABILITY OR FITNESS FOR YOUR INTENDED PURPOSE OR USAGE. WÜRTH ELEKTRONIK EISOS DOES NOT WARRANT OR REPRESENT THAT ANY LICENSE, EITHER EXPRESS OR IMPLIED, IS GRANTED UNDER ANY PATENT RIGHT, COPYRIGHT, MASK WORK RIGHT, OR OTHER INTELLECTUAL PROPERTY RIGHT RELATING TO ANY COMBINATION, MACHINE, OR PROCESS IN WHICH THE WÜRTH ELEKTRONIK EISOS' PRODUCT WITH THE INCORPORATED FIRMWARE IS USED. INFORMATION PUBLISHED BY WÜRTH ELEKTRONIK EISOS REGARDING THIRD-PARTY PRODUCTS OR SERVICES DOES NOT CONSTITUTE A LICENSE FROM WÜRTH ELEKTRONIK EISOS TO USE SUCH PRODUCTS OR SERVICES OR A WARRANTY OR ENDORSEMENT THEREOF.

Limitation of liability

Any liability not expressly provided by Würth Elektronik eiSos shall be disclaimed.

You agree to hold us harmless from any third-party claims related to your usage of the Würth Elektronik eiSos' products with the incorporated firmware, software and source code. Würth Elektronik eiSos disclaims any liability for any alteration, development created by you or your customers as well as for any combination with other products.

Applicable law and jurisdiction

Applicable law to these license terms shall be the laws of the Federal Republic of Germany. Any dispute, claim or controversy arising out of or relating to these license terms shall be resolved and finally settled by the court competent for the location of Würth Elektronik eiSos registered office.

Severability clause

If a provision of these license terms is or becomes invalid, unenforceable or null and void, this shall not affect the remaining provisions of the terms. The parties shall replace any such provisions with new valid provisions that most closely approximate the purpose of the terms.

Miscellaneous

Würth Elektronik eiSos reserves the right at any time to change these terms at its own discretion. It is your responsibility to check at Würth Elektronik eiSos homepage for any updates. Your continued usage of the products will be deemed as the acceptance of the change.

We recommend you to be updated about the status of new firmware and software, which is available on our website or in our data sheet and manual, and to implement new software in your device where appropriate.

By ordering a product, you accept these license terms in all terms.

List of Figures

1	Setebos-I	9
2	Block diagram of the module	10
3	Pinout (top view)	15
4	Minimal pin connections	18
5	Host Interface	22
6	Layout	27
7	Placement of the module with integrated antenna	28
8	Dimensioning the antenna connection as micro strip	28
9	Himalia dipole antenna	31
10	Reference design: Schematic page 1	33
11	Reference design: Schematic page 2	34
12	Reference design: Layout	35
13	Antenna characteristic from integrated antenna measured on official EV-Board ¹	36
14	Trace design: Layout	37
15	Reference design: Stack-up	37
16	Trace design: Schematic	38
17	On-board PCB antenna	39
18	External antenna connection	39
19	Reset IC	40
20	Reflow soldering profile	42
21	Module dimensions [mm]	48
22	Footprint WE-FP-4+ [mm]	49
23	Lot number structure	50
24	Label of the Setebos-I	51
25	FCC certificate	60
26	IC certificate	61
27	ETA-WPC certificate page 1	64
28	ETA-WPC certificate page 2	65

List of Tables

3	Ordering information	10
4	Operating conditions	11
5	Absolute maximum ratings	11
6	Power consumption for 100 % transmission/reception	12
7	Timing and RSSI	12
8	Transmit and receive power	12
9	Sensitivity at different data rates	13
10	Pin characteristics	14
11	Pinout	17
12	Classification reflow soldering profile, Note: refer to IPC/JEDEC J-STD-020E	41
13	Dimensions	47
14	Weight	47
15	Lot number details	50



Contact

Würth Elektronik eiSos GmbH & Co. KG
Division Wireless Connectivity & Sensors

Max-Eyth-Straße 1
74638 Waldenburg
Germany

Tel.: +49 651 99355-0
Fax.: +49 651 99355-69
www.we-online.com/wireless-connectivity

WÜRTH ELEKTRONIK MORE THAN YOU EXPECT